

The **CE** symbol on our products signifies that they have been certified according to the EMC directive 89/336/EEC, the Telecommunications directive 91/263/EEC, and the Low Voltage directive 73/23/EEC when applicable. The products fulfil the requirements according to the following standards:

**Cellular Phones and Accessories in Combination:**

*ETS 300 342-1 EMC for European digital cellular telecommunications.*

**Accessories Without Direct Connection to a Cellular Phone:**

*EN 50081 Electromagnetic compatibility, Generic Emission Standard, and EN 50082 Electromagnetic compatibility, Generic Immunity Standard.*

***This manual describes Ericsson Gh688***

**First edition** (December 1996)

This manual is published by **Ericsson Mobile Communications AB**, without any warranty. Improvements and changes to this manual necessitated by typographical errors, inaccuracies of current information, or improvements to programs and/or equipment, may be made by **Ericsson Mobile Communications AB** at any time and without notice. Such changes will, however, be incorporated into new editions of this manual.

All rights reserved.

**Ericsson Mobile Communications AB**, 1996.

Publication number: **EN/LZT 126 1353 R1A**

Printed in Sweden

INNOVATRON PATENTS

# Guidelines for Safe and Efficient Use

*Important: Read this information before using your portable phone.*

## General

Since its introduction in the mid 1980s the portable phone is one of the most exciting and innovative products ever developed. With it, you can stay in contact with your office, your home, emergency services, and others.

Your telephone is a radio transmitter and receiver. When it is ON it receives and also sends out radio frequency (RF) energy. Depending upon the type of mobile phone you have purchased, it operates in different frequency ranges and employs commonly used modulation techniques. When you use your phone, the system handling your call controls the power level at which your phone transmits.

## For the safe and efficient operation of your phone, observe these guidelines

### Exposure to radio frequency energy

The International Commission on Non-Ionizing Radiation Protection (ICNIRP), sponsored by the World Health Organization (WHO), published a statement in 1996 which sets limits for exposure to RF fields from handheld mobile

phone. According to this statement, which is based on the available body of research, there is no evidence that mobile terminals meeting the recommended limits can cause any adverse health effects. All Ericsson telephones conform to the ICNIRP recommendations, and international exposure standards, such as:

CENELEC European Pre-standard  
ENV50166-2

ANSI/IEEE C95.1-1992 (USA, Asia-Pacific)

If you want to limit RF exposure even further, you may choose to control the duration of your calls and operate your phone in the most power efficient manner.

### Efficient phone operation

How to use your phone for optimum performance with minimum power consumption:

Hold the phone as you would any other telephone. While speaking directly into the mouthpiece, angle the antenna in a direction up and over your shoulder. If the antenna is extendable, it should be extended during a call.

**Do not** hold the antenna when the phone is **IN USE**. Holding the antenna affects call quality, may cause the phone to operate at a higher

power level than needed and shorten talk and standby times.

### Antenna care and replacement

Do not use the phone with a damaged antenna. Replace a damaged antenna immediately. Consult your manual to see if you may change the antenna yourself. If so, use only an Ericsson approved antenna. Otherwise, take your phone to a qualified service centre for repair.

Use only the designated Ericsson antenna. Unauthorized antennas, modifications, or attachments could damage the phone and may violate the appropriate regulations.

Do not use an antenna designed for any other type of portable telephone than the telephone you have purchased.

### Driving

Check the laws and regulations on the use of telephones in the areas where you drive. Always obey them. Also, when using your phone while driving, please:

Give full attention to driving.

Use hands-free operation, if available.

Pull off the road and park before making or answering a call if driving conditions so require.

RF energy may affect some electronic systems in motor vehicles. In addition, some vehicle manufacturers forbid the use of mobile phones in their vehicles. Check with your vehicle manufacturer's representative to be sure your phone will not affect the electronic systems of your vehicle.

### **Electronic devices**

Most modern electronic equipment, for example, equipment in hospitals and cars, is shielded from RF energy. However, RF energy from telephones may affect some electronic equipment. Turn your phone OFF in health care facilities when regulations posted in the areas instruct you to do so. Always request permission before using your phone near medical equipment.

Mobile telephones may affect the operation of some implanted cardiac pacemakers, equipment for people with hearing impairments and other medically implanted equipment. Pacemaker patients should be aware that the use of a mobile phone very close to a pacemaker may cause the device to malfunction. Avoid placing the phone over the pacemaker, i.e. in your breast pocket. When using the phone, place it at your ear opposite the pacemaker. If a distance of 15cm. is kept between the phone and the pacemaker, the risk of interference is limited. Contact your cardiologist for more information.

### **Aircraft**

Turn your phone OFF before boarding any aircraft.

Use it on the ground only with crew permission. Turn off your phone before the aircraft leaves the ground. Do not use it in the air.

To prevent possible interference with aircraft systems, safety regulations require you to have permission from a crew member to use your phone while the plane is on the ground. To prevent interference with communication systems, you must not use your phone while the plane is in the air.

### **Power Supply**

Connect AC (Power supply) only to designated power sources as marked on the product.

To reduce risk of damage to electric cord, remove from outlet by holding onto AC adapter rather than cord.

Make sure the cord is located so that it will not be stepped on, tripped over or otherwise subjected to damage or stress.

To reduce risk of electric shock, unplug unit from power source before attempting any cleaning, then use soft cloth dampened on with water.

### **Children**

Do not allow children to play with your phone. It is not a toy. Children could hurt themselves or others (by poking themselves or others in the

eye with the antenna for example). Children could also damage the phone or make calls that increase your telephone bills.

### **Blasting areas**

To avoid interfering with blasting operations, turn your unit OFF when in a "blasting area" or in areas posted "turn off two-way radio". Construction crews often use remote control RF devices to set off explosives.

### **Potentially explosive atmospheres**

Turn your phone OFF when in any area with a potentially explosive atmosphere. It is rare, but your phone or its accessories could generate sparks. Sparks in such areas could cause an explosion or fire resulting in bodily injury or even death.

Areas with a potentially explosive atmosphere are often, but not always, clearly marked. They include fuelling areas, such as petrol stations, below deck on boats, fuel or chemical transfer or storage facilities, and areas where the air contains chemicals or particles, such as grain, dust, or metal powders.

Do not transport or store flammable gas, liquid, or explosives in the compartment of your vehicle which contains your phone and accessories.

### **Product care**

**Do Not** expose product to water or moisture.



To recall a phone number using the position	17	To choose answering mode when using the phone with handsfree equipment	22	<b>13. Using Other Networks (NETWORKS Menu)</b>	<b>31</b>
To change a phone number, name or memory position	17	To personalise the greeting displayed each time the phone is turned on	22	To select a network	31
To erase a phone number	17	To have your phone number displayed each time the phone is turned on	23	To choose automatic or manual network search mode	31
To erase ALL phone numbers from the Phone memory	18	To select another language in the display	23	To create a list of preferred networks on your SIM card	32
To copy ALL phone numbers from the Card memory to the Phone memory and vice versa	18	To personalise the names of the two lines if you have the 2 Line service	23	To start an automatic network search	33
To copy phone numbers ONE BY ONE from the Card memory to the Phone memory and vice versa	18	To activate data menus	23	<b>14. Sending DTMF Tones</b>	<b>35</b>
The ANSWERED CALLS Memory	19	To reset the phone	23	Automatic DTMF	35
The DIALLED NUMBERS memory	19	<b>10. Protecting Your SIM Card and Phone (ACCESS and KEYLOCK Menus)</b>	<b>24</b>	DTMF pause function	35
<b>9. Personalising Your Phone (SETTINGS Menu)</b>	<b>20</b>	Card Lock	24	Using several pauses	35
To set the level of the ringing signal	20	Phone Lock	25	Pre-programmed DTMF signalling	35
To set the volume of the ear piece or handsfree loudspeaker	21	Call Barring	25	<b>15. Who Is Calling?</b>	<b>36</b>
To choose the type of ringing signal	21	Locking the keypad	26	To receive a call	36
To compose your own ringing signal	21	<b>11. Setting Time, Date and Alarm (CLOCK Menu)</b>	<b>27</b>	Answered calls	36
To choose the type of message signal	21	Clock (Time of Day)	27	Unanswered calls	37
To choose manual or automatic key lock	21	Calendar (Today's Date)	27	To hide your phone number when making a call	37
To choose the key sound	21	Alarm	28	To send your phone number when making a call	37
To set the illumination of the display and keypad	22	<b>12. Diverting Incoming Calls (DIVERT Menu)</b>	<b>29</b>	<b>16. Handling Two Calls Simultaneously</b>	<b>38</b>
To be reminded of the conversation time spent during a call	22	To activate a particular call divert	29	To activate the Call Waiting service	38
To choose call time or call cost display	22	To check the status of a call divert	30	To make a second call while a call is in progress	38
		To cancel a call divert	30	To receive a second call while engaged in a call	38
		To cancel ALL call diverts	30	To switch between two calls	38
		To review the status of ALL call diverts	30	To end the current call	38
				To receive a third call	39

Transferring a Call	39	To review received messages	46	<b>26. Composing Your Own Ringing Signal</b>	<b>52</b>
<b>17. Conference Calls</b>	<b>39</b>	<b>21. Two Line Service</b>	<b>47</b>	About the phone's note system	52
To initiate a conference call	39	To select a line	47	Simple melody	52
To have a private conversation with one of the members	40	Different settings for each line	47	<b>27. Problems You Can Solve</b>	<b>54</b>
To release one of the members	40	To personalise the names of the two lines	47	The phone does not come on	54
To end the conference call	40	<b>22. Knowing the Call Time/Call Cost</b>	<b>48</b>	<i>Phone locked</i> is displayed, followed by the prompt <i>Enter lock code</i>	54
<b>18. Answering Service</b>	<b>40</b>	To check the time or cost of the last call	48	<i>Insert card</i> is displayed	54
To activate the Voicemail function	40	To check the total call time or call cost	48	<i>Wrong PIN or Wrong PIN2</i> is displayed	54
To call your answering service	41	To reset the total call time/cost meter	48	<i>Card blocked. Unblock?</i> is displayed	<b>54</b>
<b>19. Sending and Receiving Text Messages (SMS)</b>	<b>41</b>	To determine the call cost	48	<i>BLOCKED. Contact card provider</i> is displayed	55
To set phone for text messaging	42	Specifying a total amount of money that can be used for making calls	49	<i>Enter PUK2</i> is displayed	55
To receive a message	42	<b>23. Restricted Usage with Fixed Numbers</b>	<b>50</b>	<i>Emergency calls only</i> is displayed	55
To read stored messages	43	Activating the Fixed Dialling function	50	<i>No network</i> is displayed	55
Own messages	43	Storing fixed numbers	50	A key symbol is displayed in the middle line of the display	56
<b>20. Using Area Information (AI)</b>	<b>45</b>	To change a stored number	51	You have chosen a wrong language in the display	56
To turn area information on or off	45	<b>24. Data Menus</b>	<b>51</b>	Indicator light blinks red	56
To decide which types of AI message you wish to receive	45	<b>25. Using the Phone's Built-In Calculator</b>	<b>52</b>		
To receive area information	46	To make a calculation	52		

# 1. The Phone

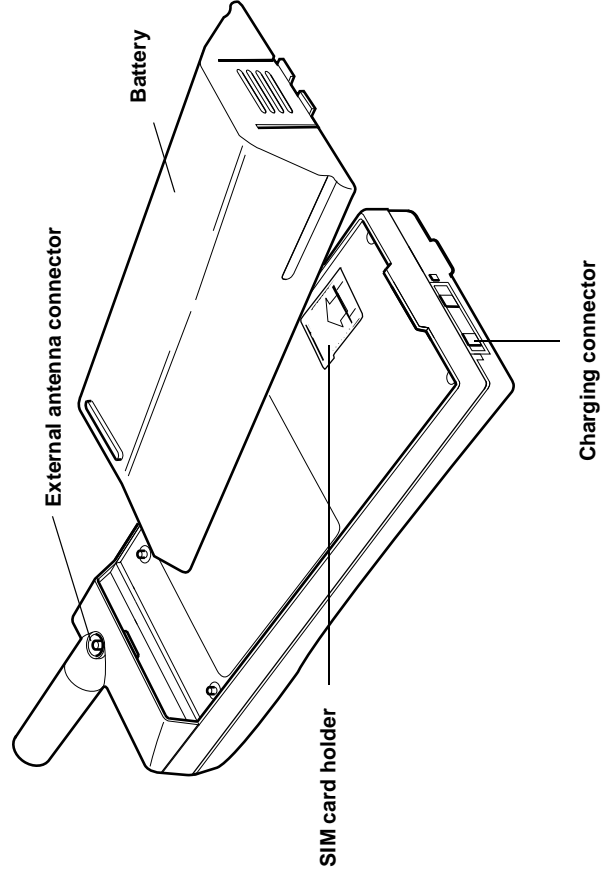
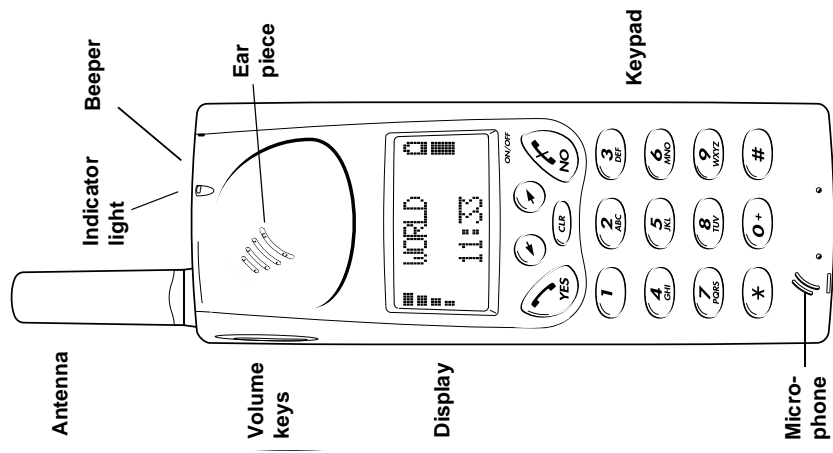

## 2. Making the Phone Ready for Use

*This chapter describes how you assemble the phone, what the SIM Card is, and how you handle the battery.*

### To insert the SIM card

When you become a subscriber of a network operator, you obtain a SIM card with a personal security code, the **PIN code**. The SIM card contains a computer chip that keeps track of your phone number, the services that you have ordered from your network operator, and your phone book information.

Before you can use the phone, you must insert the SIM card into the phone.

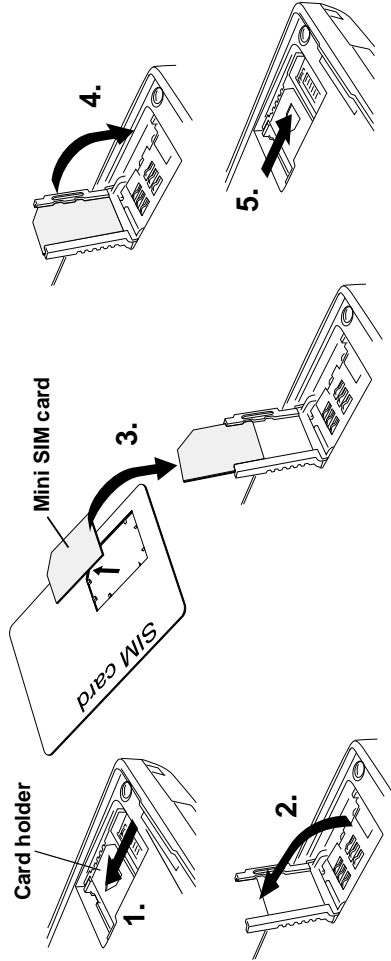

1. Release the card holder by sliding it from you.
2. Unfold the holder.
3. Slide the mini SIM card into the holder.  
Make certain that the angled corner is top right.
4. Fold down the card holder.
5. Lock the card holder by sliding it towards you.

### To attach the battery

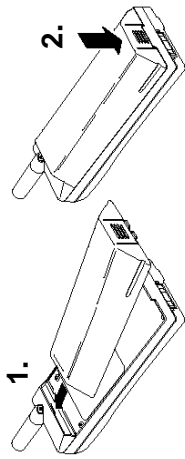

1. Place the battery on top of the phone
2. Press until you hear a click.

### Removing the battery:

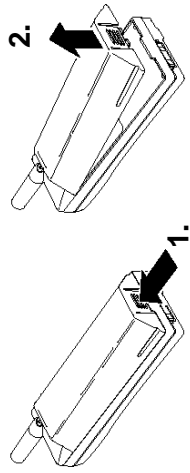

- Make sure the phone is turned off.
1. Press the locking catch on the bottom of the battery.
  2. Lift the battery up and away from the phone.

### To charge the battery

Have the battery attached to the phone.

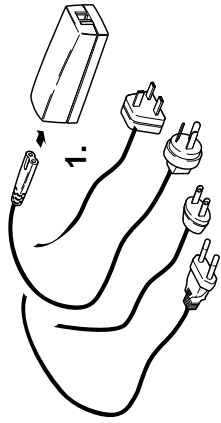

1. Connect the charger to the mains.  
A green indicator lamp on the charger lights up.
2. Connect the charger to the phone. The flash symbol on the plug must face upwards.  
The phone now starts to charge the battery. To indicate this, a battery icon in the display is filled and emptied continuously and the indicator lamp on the top of the phone shows a steady red light. When the battery is fully charged, the indicator light shows a steady green light.

*While you are charging the battery you can turn the phone on and use it. However, the charging time will be longer.*

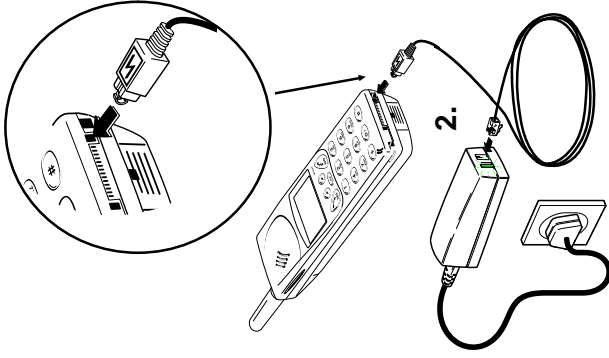

### Disconnecting the charger:

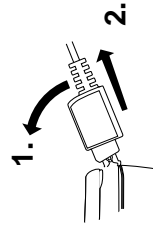

Lift the plug up and pull it out .

### About the battery

Your phone is supplied with a Nickel Metal Hydride battery. The battery is not charged before shipment, even though there might be enough power to turn the phone on.

### Low Battery Alarm

As a reminder that the battery soon needs recharging or replacing, an alarm signal (a long beep) sounds and the message 'Battery low' appears for ten seconds in the display.

In addition, the indicator light on the top of the phone starts **blinking red**. If the phone is left

on, the **low battery alarm** will be repeated several times and, finally, the phone will turn itself off when the battery is no longer able to power it satisfactorily. It is not possible to turn the phone on again. Instead the battery must be recharged, or replaced with a charged one.

## 3. Turning the Phone On

*This chapter describes how to turn the phone on and off, how to choose another language than English in the display, if this is desired, and how to set the phone's clock.*

### To turn the phone on

1. Press and hold down the NO (ON/OFF) key until you hear a click. The display will prompt you to enter your PIN (the security code that follows your SIM Card).

Enter:  
PIN

2. Enter your PIN. The digits appear as stars (\*) in the display. If you enter a wrong digit, you can erase it by pressing the CLR key.

3. Press # or YES.  
If you entered your PIN correctly, you will be welcomed by your phone. Then the phone searches for a network.

When a network is found, the phone beeps three times. The indicator light on top of the phone blinks green once every second.

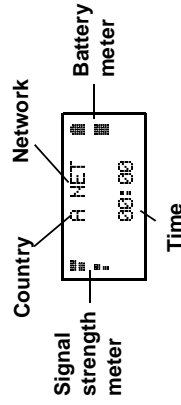

The display shows:

You can now make and receive calls. This is called **standby mode**.

- If you are not using the phone, the illumination of the display and keypad is automatically turned off after 10 seconds. Pressing any key will turn the illumination on again.

**If the indicator light does not start to blink green and the name of a network does not appear in the display:**

- If the message **'Emergency calls only'** is displayed, you are in coverage of a network but you are not allowed to use that network. However, in an emergency, you can call the international emergency number **112**. Refer to chapter **5. Making and Receiving Calls**.
- If the message **'No network'** is displayed, there is no network within range, or the received signal is too weak. You have to move to obtain a sufficiently strong signal.

### To choose a language other than English in the display

Your phone is normally delivered with English text in the display. To select a different language:

1. Press the **▲** or **▶** key repeatedly until **'Settings'** appears in the display:

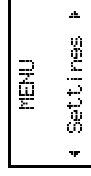

2. Press **YES** to select the **SETTINGS** menu.

3. Press **▲** or **▶** repeatedly until **'Language'** appears.

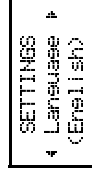

4. Press **YES** to select the **'Language'** function.
5. Press **▲** or **▶** repeatedly until the desired language, for example German, appears.

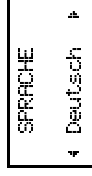

6. Press **YES** to select that language.
7. Press **CLR** to leave the **SETTINGS** menu.

### If you selected a wrong language by mistake

To return to English text, enter the following sequence:  
\*#0000#

### To set the time

The time is shown in the bottom line of the display. When the phone is delivered, the clock is normally not set.

1. Press **▲** or **▶** key repeatedly until **'Clock'** appears in the display:

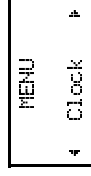

2. Press **YES** to select the **CLOCK** menu.

3. Press **▲** or **▶** repeatedly until **'Set clock'** appears.

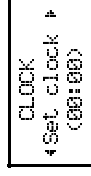

4. Press **YES** to select the **'Set clock'** function.

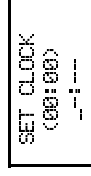

5. Enter the time in hours and minutes in the 24-hour format, for example 13:01.

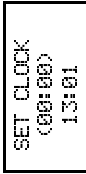

6. Press YES to confirm the setting.

7. Press CLR to leave the **CLOCK** menu.

You can have the time presented in the 12-hour (a.m./p.m.) format. You can also have today's date presented in the display. Refer to chapter 11. **Setting Time, Date and Alarm.**

### To turn the phone off

Press and hold down the **NO (ON/OFF)** key until the display is turned off.

## 4. About the Keypad and Display

### Key Functions

They keys have other functions when you have accessed the phone's menu system. Refer to chapter 7. **About the Phone's Menus.**



#### YES

Used to make a call after a phone number has been entered.

Used to answer an incoming call.

ON/OFF

#### ON/OFF

Used to turn the phone on or off. Press and **hold down** the key until the display turns on or off.

To turn the phone off, the phone must be in standby mode.

#### NO

Used to end a call.

Used to eject an incoming call.



#### Left Arrow and Right Arrow

Used to access the **Menu** system.



#### Clear

Erases digits from the bottom line of the display. **Hold down** to erase all digits simultaneously.

If held down while a call is in progress, it disconnects the microphone (**Mute** function).



#### Numeric keys

Used to enter the digits **0 – 9**.

If held down, the **0** key enters the international character “+”.



#### Star

Used to enter the character \*.

If held down, it enters a **p** (pause) character.

#### Hash

Used to enter the character #.

If held down, it enters a **⌘** character.

Used to terminate the input of PIN and security codes.

Can be used to recall a phone number from the Phone Book (enter the number of the memory position and then press #).



#### Volume keys at the side of the phone

Used during a call to **increase** or **decrease** the volume of the ear piece or handsfree loudspeaker. There are five volume steps indicated by small squares in the bottom line of

the display.

You can have independent volume settings when you use the phone as a handheld unit and when you use it with various handsfree equipment. The volume settings will remain unchanged after you have turned the phone off.

## Indicators in the Display



**Signal Strength meter.** The more bars that are shown, the higher the signal strength.

**Battery meter.** The fuller the icon, the better the battery charge.

The keypad is locked. Press **▲** followed by **YES** to unlock.

The alarm function is activated.

All incoming calls are diverted to another number.

The ringing signal is turned off.

You have received a text message (SMS).

The line currently selected if you have the **Two Line** service.

# 5. Making and Receiving Calls

This chapter describes how to make and receive calls, how to make international and emergency calls,

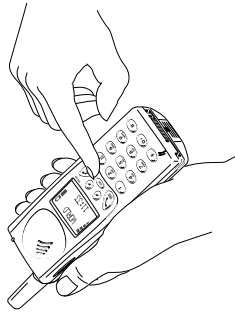

When you are abroad, you may use other networks, provided your home network has agreement that allows you to use the networks. You can read more about this in chapter 13, *Using Other Networks*.

## To make a domestic call

1. Enter the area code and phone number. The digits are shown in the display.

- To erase a digit, press **CLR**.
- To erase all digits, press and hold down **CLR** until the digits disappear.

The instructions in this chapter assume that you have turned the phone on and you are within the coverage of a network.

2. Press **YES** to make the call. The display shows **'Calling'**, followed by **'Connecting'**.

When the call is answered, a **Call Time** meter in the top line of the display shows the elapsed time in minutes and seconds.

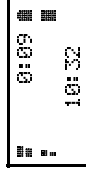

If nobody answers, the number is busy, or you cannot get through, press **NO**. The number is stored in a memory, so you can easily repeat the

call. See **Last Number Re-dial** below.

### To end a call

When the conversation is finished, press **NO**. The Call Time meter shows the duration of the call for three seconds.

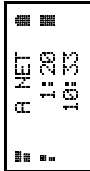

You can check the duration of the last call later on. Refer to chapter **22. Knowing the Call Time/Call Cost**.

### Last number re-dial

To recall the last called number from memory, press **YES**. The display shows '**Call?**', together with the number. Press **YES** to make the call.

### Automatic re-dialling function

If the connection of a call fails and the receiver's network admits it, the display shows '**Retry?**' Press **YES** to re-dial the number, other-

wise **NO**.

If you press **YES**, the number will automatically be re-dialled until the call is answered, or 10 times at the most. If you press any key, or you receive a call, the re-dialling is interrupted.

If the re-dialling is successful, the phone rings twice to inform you.

### To make an international call

1. Press and hold the **0** key until the international character + is displayed. (The + will be replaced by the international prefix for the country you are calling from.)
2. Enter the country code, the area code (without any leading zero) and the phone number.
3. Press **YES** to make the call.

### To make an emergency call

Enter **112** (the international emergency number) and press **YES**. The display shows '**Emergency?**'.

**112** can be used in any country with or without a SIM Card inserted, provided a GSM network

is within range.

### To receive a call

When you receive a call, the phone rings, the indicator light on the top of the phone rapidly blinks green and the display shows '**Answer?**'

### To answer the call

Press **YES** to answer the call  
When the call is finished, press **NO**.

### To reject the call

Press **NO**, or press a volume key twice, when the phone rings. If the caller's network supports it, the caller will hear a busy tone.

### Unanswered calls

If you have been unable to answer, the number of unanswered calls will be shown in the display until you press **CLR**.

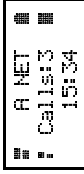

## 6. When a Call Is in Progress

*During a call you can change the volume of the ear piece, mute the microphone, use the display as a scratch pad and send DTMF tones.*

### To change the volume

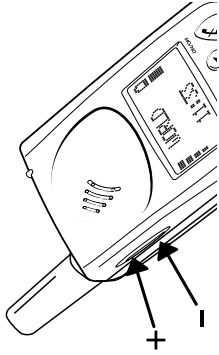

You can use the volume keys to increase or decrease the ear piece volume.

### To mute the microphone

Press and hold down the CLR key. 'Mute' is shown in the display.

To resume conversation, release the CLR key.

### To use the display as a scratch pad

You can enter a phone number on the keypad. When you end the call, the number remains in the display.

To call the number, press YES.

You can also store the number in the phone book. Refer to chapter 8. **Using the Phone Book.**

### To send tone signals

You can send DTMF tones by pressing keys 0–9, \*, and # to, for example to perform banking by phone or to control an answering machine. You can read more about the use of DTMF tones in chapter 14. **Sending DTMF Tones.**

EN/IZT 126 1353 R/A

---

## **7. About the Phone's Menus**

*You control the functions of your phone by a menu system. This chapter describes how you navigate through the menu system.*

Standby display

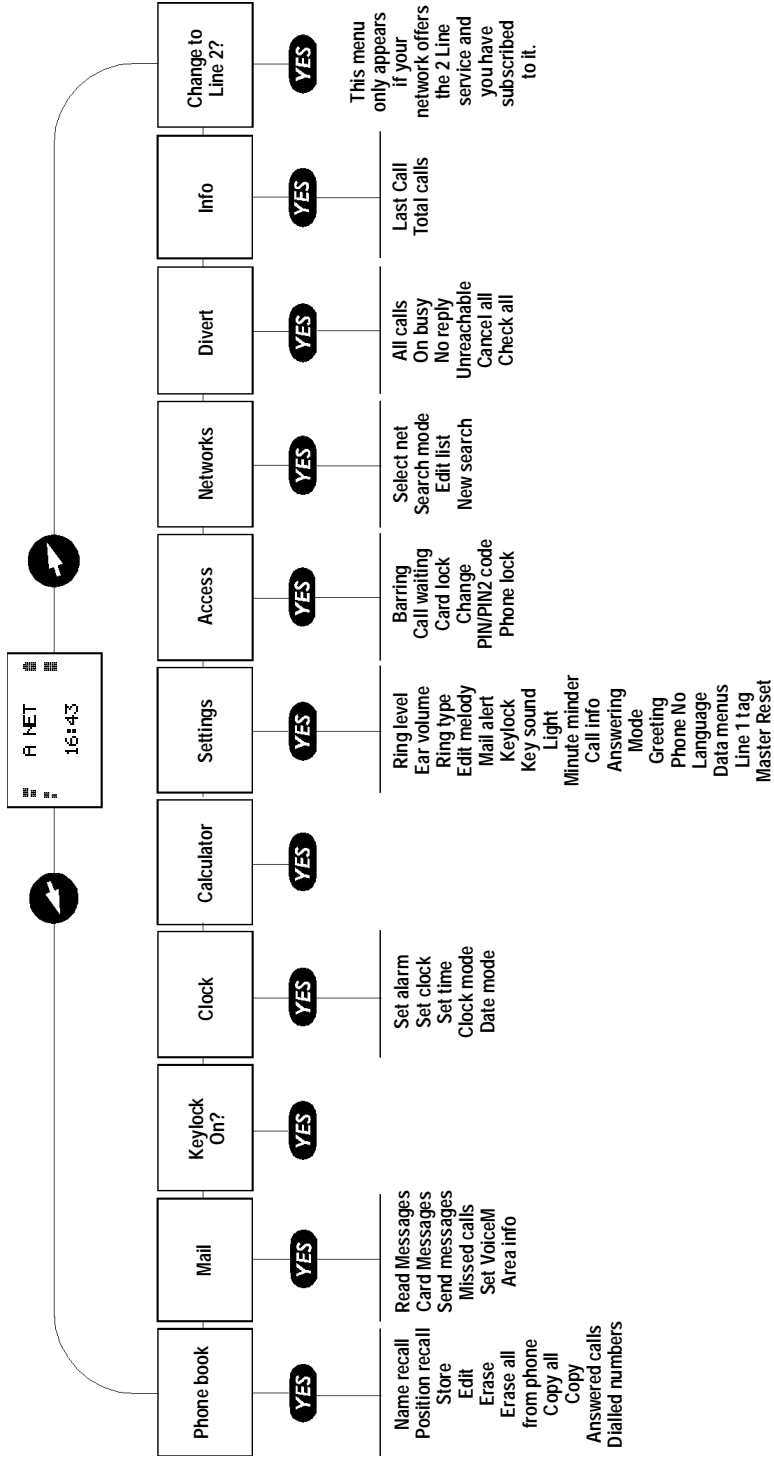

### Standby display

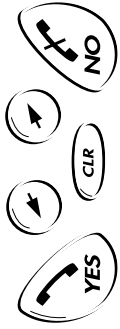
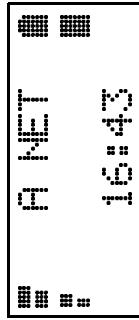

The menus are arranged in a continuous loop. The **←** and **→** keys allow you to access the menu system and then scroll from menu to menu.

When you reach the desired menu, press **YES** to select it.

Most of the menus have a number of **functions**. Scroll with **←/→** until you reach the desired function. Then press **YES** to select it.

In the same way, a function has a number of **settings** that you can reach using **←/→**. Press **YES** to confirm the setting chosen.

The **NO** key allows you to leave a setting unchanged. It can also be used to move back from a function to a menu, from a menu to the standby display.

Pressing the **CLR** key always takes you back to the standby display.

*You will leave the menu system automatically if you do not press a key within 60 seconds or if you receive a call.*

### Display texts and symbols in the menu system

You have selected a MENU

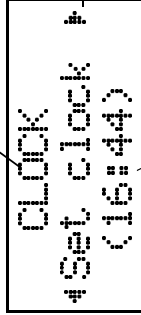

You can scroll through the FUNCTIONS

The current **SETTING** for the displayed function

UPPER-CASE letters are used to indicate the menu or function selected.

When **#** and **#** are shown, you can scroll with **←** and **→**.

Text within **brackets** indicates the current setting for the displayed function.

### To enter letters

With some functions you can enter letters and other characters using the numeric keys.

Press the appropriate key, **1–9, 0** or **#** (repeatedly) until the desired letter, character or digit appears in the display. For example, to enter an **A**, press the **2** key once. To enter a **B**, press the **2** key twice.

- 1 Space - ? ! , . : ' ' ( ) |
- 2 A B C Ä Å Æ à Ç 2 Γ
- 3 D E F è É 3 Δ Φ
- 4 G H I ì 4
- 5 J K L 5 A
- 6 M N O Ñ Ö Ø ò ó
- 7 P Q R S ß 7 Π Σ
- 8 T U V Ü ù 8
- 9 W X Y Z 9
- 0 0 + & @ / \$ % £ © ÷ Ξ Ψ Ω
- # # \*

*To enter a digit, you can also press and hold down the numeric key.*

### To enter lower-case letters

Enter the letter, for example an **A**, and then press **\***. An **a** appears.

Lower-case letters will now appear until you press **\*** again.

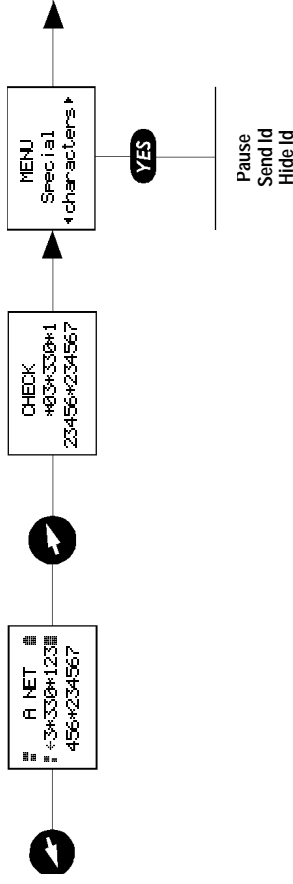

## CHECK and SPECIAL CHARACTERS Menus

If you have entered characters into the bottom line of the display, either the **SPECIAL CHARACTERS** or the **CHECK** menu appears when you enter the menu system by pressing **➔**.

If you have **not** entered any characters, that is, the time of day is shown in the bottom line, none of these menus will appear. Neither will they appear if you access the menu system by pressing **➔** and then scroll further with this key.

### To check the first characters

If you enter **more than 20** characters (0 – 9 and \*, #, + or p), the first characters will disappear from the display. Instead, a left arrow is shown

on the left in the second line, in front of the characters.

Pressing **➔** takes you to the **CHECK** menu, which lets you see the first characters.

If you wish to enter a special character, press **➔**. To return to the standby display, press **➔**.

### To insert special characters

If you have entered **less than 20** characters, pressing **➔** takes you direct to the **SPECIAL CHARACTERS** menu.

This menu lets you:

- insert a pause character (p) to separate the phone number from a code that you wish to send as DTMF tones.

```

SPECIAL CHAR
└ Pause ─┘
0123456789
  
```

Refer to chapter **14. Sending DTMF Tones**.

- insert a code that shows your phone number when making a call.

```

SPECIAL CHAR
└ Send Id ─┘
0123456789
  
```

Refer to chapter **15. Who Is Calling?**

- insert a code that hides your phone number when making a call.

```

SPECIAL CHAR
└ Hide Id ─┘
0123456789
  
```

Refer to chapter **15. Who Is Calling?**

## 8. Using the Phone Book (PHONE BOOK Menu)

This chapter describes how you can create a personal phone book by storing phone numbers and accompanying names on the SIM card (card memory) and in the phone (phone memory). The PHONE BOOK menu also includes functions for recalling the last dialled numbers. If you have the CLI (Calling Line Identification) service you can also recall the last answered numbers.

### Card memory

The memory positions in the Card memory are numbered from 1 onwards. The actual number of memory positions available depends on your SIM card.

### Phone memory

The Phone memory can hold up to 99 phone numbers. The memory positions are designated  $\alpha 1$  –  $\alpha 99$ .

In the PHONE BOOK menu, press # to enter the  $\alpha$  character. Outside the PHONE BOOK menu, you must press and hold down # to enter the  $\alpha$  character.

### International numbers:

If you intend to use your phone both home and abroad, you should store all phone numbers as international phone numbers, that is, with the international “+” character and the country code before the area code and the number.

- To enter the “+” character, press and hold down the 0 key.
- If a leading 0 is included in the area code, omit it.

### Speed dialling facility

The phone numbers that you store in positions 1 – 9 in the card memory can be called by entering the position number and then pressing YES. You should, therefore, save positions 1 – 9 for important numbers.

### To store a phone number

1. Enter the phone number to be stored.
2. Press  $\blacktriangleleft$ , followed by YES to select the PHONE BOOK menu.

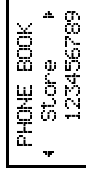

```
PHONE BOOK
4 STORE 1
123456789
```

3. Press YES to select the ‘Store’ function.
4. The first free memory position in the card

memory is suggested in the top line of the display.

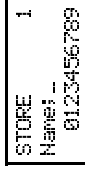

```
STORE
Name: _ 1
0123456789
```

If you wish to store the phone number in that position, go to step 5.

If you wish to store the phone number in a different position, press  $\blacktriangleright$  twice to move the cursor ( ) to the top line, enter the number of the memory position, followed by  $\blacktriangleright$ .

- To enter the number of a memory position in the phone memory, for example  $\alpha 1$ , press # to enter the  $\alpha$  character.
- If you press # twice, the first free memory position in the phone memory is appears.

5. If you wish to store the phone number without an accompanying name, go to step 7.
6. Enter the first letter of the name by pressing the appropriate numeric key as many times as

required. For example, press the **9** key three times to enter the letter **Y**. See the table in chapter **7. About the Phone's Menus**. Enter the next letter when the cursor has moved to the next letter position.

- To change between upper-case and lower-case letters, press **\***
  - To enter a **space**, press the **1** key. To enter a **hyphen**, press the **1** key **twice**.
  - To **erase** the last letter, press **CLR**.
  - You can move back with **↶** and then insert or erase letters. Move forward with **↷**.
7. Press **YES** to store the number (and name).

#### Alternative method to store a number

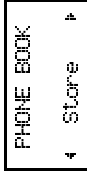

Instead of entering the phone number before going to the **PHONE BOOK** menu, you can select the **'Store'** function from the **PHONE BOOK** menu



and then enter (the name) and phone number.

#### Overwrite protection

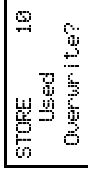

This message appears if you try to store a phone number in a position which already contains a phone number. You can then:

- Store the number in a **different** position. Press **NO** and enter the number of the position.
- Store the number in the selected position, thus **erasing** the old number (and name). Press **YES**.

#### Card memory full

If you try to store a phone number when all positions are occupied, a position number in the Phone memory will be suggested in the top line of the display.

#### Both memories full

If both memories become full, no position number will be suggested.

If you do wish to store the phone number, you have to enter the number of an already occupied position, thus **erasing** the old number (and name).

#### To recall a phone number using the name

- Press **CLR** to erase any digits from the display.
- Press **↶**, followed by **YES** to select the **PHONE BOOK** menu.

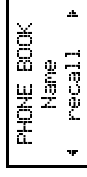

- Then press **YES** to select the **'Name recall'** function.
- Enter one or more of the letters in the name in their correct order and press **YES**.

If the name shown is not the desired one, scroll through the phone book using **↶** or **↷** until you find the name.

- Press **YES** to call the number or **NO** to return to stand-by.

#### Alternative method to recall a number

Press **CLR** to erase any digits from the display. Press **↶**, followed by a numeric key. For example, to recall a name beginning with **A**, press the **2** key. To recall a name beginning with **E**, press the **3** key twice.

If the name displayed is not the desired one, scroll with **↶** or **↷**.

## To recall a phone number using the position

1. Press CLR to erase any digits from the display.
2. Press  $\blacktriangleleft$ , followed by YES to select the PHONE BOOK menu.
3. Then press  $\blacktriangleright$ ,

```
PHONE BOOK
Position
4 Recall
```

followed by YES to select the 'Position recall' function.

4. Enter the position number and press YES.
  - To enter a number in the **phone memory**, for example  $\alpha 1$ , press # to enter the  $\alpha$  character.
  - If you entered the wrong position number, scroll through the card or phone memory using  $\blacktriangleright$  or  $\blacktriangleleft$  until you find the phone number.
5. Press YES to call the number or NO to return to standby.

## Recalling a number without entering the phone book menu

1. Enter the position number and then press #.
  - To enter a number in the **phone memory**, for example  $\alpha 1$ , you must **hold down #** to enter the  $\alpha$  character.

2. Press YES to call the number, or scroll with  $\blacktriangleright$  until you find the number you wish to call. Then press YES to call it.

## Speed dialling

1. Enter the position number 1–9.
2. Press YES to make the call.

## To change a phone number, name or memory position

Select 'Edit' from the PHONE BOOK menu.

```
EDIT
4 Find Pos
Position:
```

- a. Enter the position number and press YES.
- b. If you wish to enter the name, press  $\blacktriangleright$ .

```
EDIT
4 Find name
Name:
```

Enter the full name and press YES.

```
EDIT 11
Name: CHRIS
012345678901
```

You can now change the **position number** (in the top line), the **name** (in the middle line) or the **phone number** (in the bottom line).

When the cursor is positioned to the right of the characters in a line, you can move the cursor to

the next line by pressing  $\blacktriangleright$  and then make the changes in that line.

Press CLR (repeatedly) to **erase** the last character(s) in a line. Then enter the new characters. You can also **move** the cursor **back** with  $\blacktriangleleft$

```
EDIT 11
Name: CHRIS
012345678901
```

and erase characters to the left of the cursor, or insert characters in the cursor's position.

```
EDIT 11
Name: CHRIS
012345678901
```

When you are finished with the changes, press YES.

## To erase a phone number

Select 'Erase' from the PHONE BOOK menu

```
ERASE
Position: -
```

Enter the position number and press YES, or scroll with  $\blacktriangleright$ / $\blacktriangleleft$  until you find the position number with the (name) and number you wish to erase.

```
ERASE 11
4 CHRIS
Erase?
```

Press YES to erase the (name) and number.

### **Alternative method to erase a phone number**

Recall the number using 'Name recall' or 'Position recall'.

```
CHRIS  
  (11) +  
012345678901
```

Press and hold down CLR. The question 'Erase?' appears. Press YES to erase the (name) and number.

### **To erase ALL phone numbers from the Phone memory**

From the PHONE BOOK menu, select 'Erase all from phone'.

```
ERASE ALL  
Erase ?  
0 positions?
```

Press YES to erase all numbers (and names).

### **To copy ALL phone numbers from the Card memory to the Phone memory and vice versa**

Select 'Copy all' from the PHONE BOOK menu.

```
COPY ALL  
+Card+Phone+
```

### **To copy from the Card memory to the Phone memory**

Press YES.

```
COPY CARD  
From start  
Position: --
```

Enter the number of the first position in the Card memory you wish to copy, for example 1, and press YES.

```
COPY CARD  
To start  
Position: 1
```

Enter the number of the first position in the Phone memory you wish to copy to, for example 10, and press YES.

```
Old pos will  
be erased  
Start copy?
```

Press YES to start the copying.

### **To copy from the Phone memory to the Card memory**

Select 'Copy all' from the PHONE BOOK menu.

```
COPY ALL  
+Card+Phone+
```

Press  $\blacktriangleright$  or  $\blacktriangleleft$ .

```
COPY ALL  
+Phone+Card+
```

Press YES.

```
COPY PHONE  
From start  
Position: 1
```

Enter the number of the first position in the Phone memory you wish to copy and press YES.

```
COPY PHONE  
To start  
Position: --
```

Enter the number of the first position in the Card memory you wish to copy to and press YES.

Press YES to start the copying.

### **To copy phone numbers ONE BY ONE from the Card memory to the Phone memory and vice versa**

Select 'Copy' from the PHONE BOOK menu.

COPY  
↓Card→Phone↑

### To copy from the Card memory to the Phone memory

Press YES.

COPY CARD  
From start  
Position: --

Enter the number of the first position in the Card memory you wish to copy and then press YES.

COPY CARD  
To start  
Position: 1

Enter the number of the first position in the Phone memory you wish to copy to and then press YES.

TOM  
1  
Copy to 010?

Press YES to copy. The next position in the Card memory is displayed.

JERRY  
2  
Copy to 011?

Press:

EN/LZT 126 1353 R1A

- YES to copy.
- NO or ↗ to go on to the next position in the Card memory.
- CLR to copy to another position in the Phone memory. Enter the number of the position and press YES.
- CLR twice to interrupt copying.

### To copy from the Phone memory to the Card memory

Select 'Copy' from the PHONE BOOK menu.

COPY  
↓Card→Phone↑

Press ↗ or ↙.

COPY  
↓Phone→Card↑

Press YES.

COPY PHONE  
From start  
Position: 0

To copy from the Phone memory to the Card memory, use the YES, NO, ↗ and CLR keys in the same way as when copying from the Card memory to the Phone memory as described in the preceding section.

## The ANSWERED CALLS Memory

If you subscribe to the **Calling Line Identification (CLI)** service of your network, the numbers of the last 5 answered calls are stored in a memory in the phone, the **Answered Calls memory**.

### To recall the last answered numbers

PHONE BOOK  
Answered  
↓ calls ↑

Refer to chapter 15. Who Is Calling?

## The DIALLED NUMBERS memory

The last 5 numbers called are stored in on the SIM card if the SIM card allows this. Otherwise, they are stored in a memory in the phone.

### To recall the last dialled numbers

- 1 Press CLR to erase any digits from the display.
2. Press ↗, followed by YES to select the **PHONE BOOK** menu. Then press ↗, followed by YES to select the **'Dialled Numbers'** function. The number last called is shown.

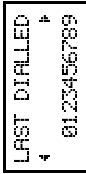

3. Press YES to call the number, or scroll with **↔** until you find the number you wish to call.

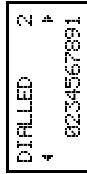

Then press YES to call it.

### To recall the last 5 dialled numbers without entering the PHONE BOOK menu

1. Press CLR to erase any digits from the display.
2. Press YES. The number last called is shown.
3. Press YES to call the number, or scroll with **↔** until you find the number you wish to call. Then press YES.

### To erase ALL numbers from the Dialled Digits memory

Select 'Dialled numbers' from the **PHONE BOOK** menu.

Press and hold down CLR.

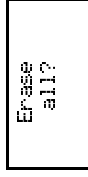

Press YES.

## 9. Personalising Your Phone (SETTINGS Menu)

The **SETTINGS** menu includes a number of functions which let you adapt your phone to your personal needs in different situations.

The functions in the **SETTINGS** menu are described in the order in which they appear when you scroll with the **↔** key.

### To set the level of the ringing signal

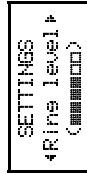

Select 'Ring level' from the **SETTINGS** menu. You can set the level of the ringing signal in six

steps. The first step means that two clicks will be heard when you receive a call.



You can also turn the ringing signal off (0) or choose a ringing signal that rises in steps from the lowest to the highest level (▲).

Use **↔**/**↔** to decrease or increase the level. If you increase the level using **↔**, you will hear the phone ring.

Use the volume keys at the side of the phone to change the level silently if you do not wish to disturb other people.

If you turn the ringing signal off, all audible signals will also be turned off. You will, however, be informed of an incoming call by the indicator light on the top of the phone and the display.

As a reminder that the ringing signal is turned off, an icon in the shape of a crossed music symbol is shown on the right in the bottom line of the display.

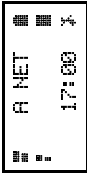

You can have one volume setting when the phone is used as a handheld unit and another setting when the phone is powered from an external source, for example, when it is used as a handsfree phone in a car.

### To set the volume of the ear piece or handsfree loudspeaker

Select 'Ear volume' from the **SETTINGS** menu.

During a call you can adjust the volume by pressing the keys at the side of the phone. The 'Ear volume' function lets you set the volume when the phone is in standby mode.

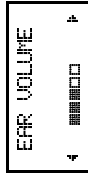

You can use either the  $\blacktriangle/\blacktriangleright$  keys or the volume keys at the side of the phone to adjust the volume.

You can have independent volume settings when you use the phone as a handheld unit and when you use it with various handsfree equipment.

### To choose the type of ringing signal

Select 'Ring type' from the **SETTINGS** menu.

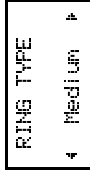

You can set the tone of the ringing signal in three steps: low, medium or high. You can also choose a mixed tone or a melody.

If you scroll with the  $\blacktriangle/\blacktriangleright$  keys you will hear the various types of ringing signals. If you do not wish to disturb other people, use the volume keys at the side of the phone to scroll silently.

You can have one tone setting when the phone is used as a handheld unit and another setting when the phone is powered from an external source.

### To compose your own ringing signal

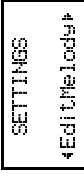

You can compose your own ringing signal. Refer to chapter 26. **Composing Your Own Ringing Signal.**

### To choose the type of message signal

Select 'Mail alert' from the **SETTINGS** menu.

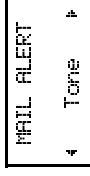

You can choose whether clicks, tones or neither (silent) will be heard when you receive a text message (SMS).

### To choose manual or automatic key lock

Select 'Keylock' from the **SETTINGS** menu.

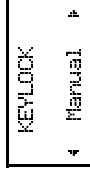

You can choose either manual or automatic keypad lock.

In automatic mode the keypad is locked 25 seconds after the last key was pressed. In manual mode you have to select the **KEYLOCK** menu to activate the lock.

Refer to the section **Locking the keypad** in chapter 10. **Protecting Your SIM Card and Phone.**

### To choose the key sound

Select 'Key sound' from the **SETTINGS** menu.

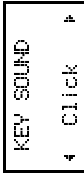

You can choose whether clicks, tones or neither (silent) will be heard when you press the keys.

### To set the illumination of the display and keypad

Select 'Light' from the **SETTINGS** menu.

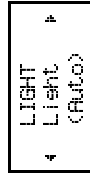

The illumination can be set to automatic, turned off, or turned on all the time.

In the automatic mode, the illumination is turned off 20 seconds after the last key was pressed. It will be turned on again when a key is pressed, or when a call or message is received.

*You can have one setting when the phone is used as a handheld unit and another setting when the phone is powered from an external source.*

### To be reminded of the conversation time spent during a call

Select 'Min(ute) Minder' from the **SETTINGS** menu.

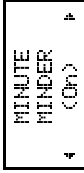

This function gives an indication of the time spent during conversation by emitting a short beep every full minute.

### To choose call time or call cost display

Select 'Call info' from the **SETTINGS** menu.

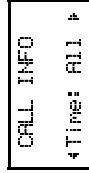

During an outgoing call, the call time is shown in the display. The 'Last Call' and 'Tot(al) Calls' functions in the **INFO** menu let you check the elapsed time of **outgoing** calls.

With the 'Call Info' function you can choose to have the call time displayed for **all** calls, both incoming and outgoing.

You can also have the **call cost** displayed, provided you have subscribed to this feature.

### To choose answering mode when using the phone with handsfree equipment

Select 'Answering mode' from the **SETTINGS** menu.

This submenu includes two functions, **Any key** and **Auto**, which are useful when the phone is used with **handsfree** equipment.

### To be able to answer a call by pressing ANY key

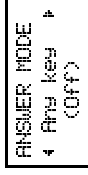

If you turn this function on, you can answer an incoming call by pressing any key **except** the **NO** key if the phone is used with **handsfree** equipment.

### To choose automatic answering

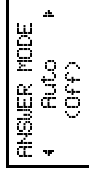

If you choose automatic answering mode, an incoming call will be answered automatically after one ringing signal if the phone is used with **handsfree** equipment.

### To personalise the greeting displayed each time the phone is turned on

*If the greeting text can be retrieved from your SIM card, you cannot change it.*

Select 'Greeting' from the **SETTINGS** menu.

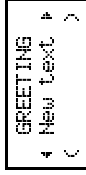

Instead of the greeting **Welcome**, you can have your phone display a welcome greeting that you choose yourself.

Enter the greeting text using the numeric key s. Refer to the table in chapter 7. **About the Phone's Menu.**

The **Greeting** function also lets you turn the greeting text off.

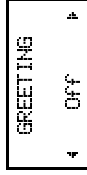

### To have your phone number displayed each time the phone is turned on

If your phone number cannot be retrieved from your SIM card, you can enter it yourself.

Select **'Phone no'** from the **SETTINGS** menu.

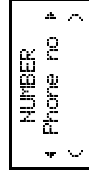

Enter the number and press **YES**.

### Fax and/or data number:

If your SIM card allows it, you can also enter your fax and/or data number.

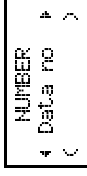
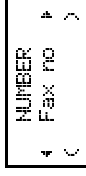

### To select another language in the display

The phone is normally delivered with English text in the display.

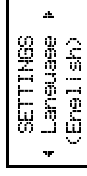

The **'Language'** function lets you select a language other than English, for example German.

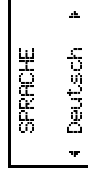

In addition, you can choose an **Auto**(matic) alternative. The language in the display will then be determined by your SIM card.

*To reset to English, you can enter the sequence **\*#0000#** at any time.*

### To personalise the names of the two lines if you have the 2 Line service

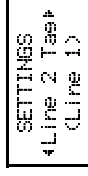

*This function only appears if you have the **2 Line service**.*

Refer to chapter 21. **2 Line Service.**

### To activate data menus

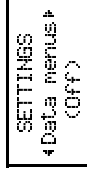

This function lets you turn two data menus on. You should do so if you use your phone with the **Mobile Office** kit and a personal computer. Refer to chapter 24. **Data Menus.**

*If you **do not** use your phone with a **Mobile Office kit**, you should **not** turn the data menus on.*

### To reset the phone

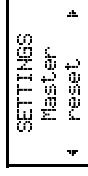

You can reset all settings to their factory-programmed values.

To reset the phone, you must enter the same se-

curity code that is used to turn the phone lock on or off. Refer to the description of the phone

lock in chapter **10. Protecting Your SIM Card**

**and Phone.** The factory-programmed security code is **0000**.

## 10. Protecting Your SIM Card and Phone (ACCESS and KEYLOCK Menus)

The ACCESS menu includes a number of security functions that you can use to protect your SIM card and phone. You can also control the cost of the calls by preventing the making and receiving of certain calls (Call Barring). The KEYLOCK menu lets you lock the keypad so that unintentional key action has no effect.

### Card Lock

Your SIM card is protected by a card lock. When you purchase your SIM card, you obtain a 4- to 8-digit PIN code.

SIM stands for Subscriber Identity Module. PIN stands for Personal Identification Number. Each time you turn the phone on, you have to enter the PIN code and then press # (or YES).

*If the PIN is entered incorrectly three times in succession, the SIM card will be blocked. This is indicated by the message 'Card blocked Unblock?'. Should this happen, refer to chapter 27. Problems You Can Solve.*

### To change the PIN code

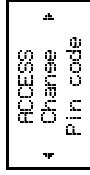

If you do not like the original PIN, you may change it to a code you find easy to remember.

To change the PIN code, select '**Change PIN code**' from the ACCESS menu.

Enter the **old** (the current) PIN and press # (or YES).

Next, enter the **new** PIN and press # (or YES).

Finally, at the prompt '**Repeat new PIN**', enter the new PIN for the second time.

The message '**New PIN**' confirms that the PIN has been changed.

*If the message 'Matching error' appears, the new PIN was entered incorrectly.*

*If the message 'Wrong PIN' appears, followed by 'Enter Old PIN', the old PIN was entered incorrectly.*

### To change the PIN2 code

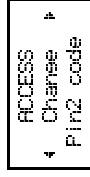

Depending on the network you use, some services require that you enter a second PIN code, the PIN2 code.

To change the PIN2 code, select '**Change PIN2 code**' from the ACCESS menu. Follow the same procedure as for changing the PIN code above.

### To activate/deactivate the Card Lock

This function only applies if your SIM card allows you deactivate the card lock.

The display shows either:

```
ACCESS
Lock
card
```

or

```
ACCESS
Unlock
card
```

Press YES. Then enter your PIN and press # (or YES).

The message 'Locked' ('Unlocked') confirms that the card lock is now activated (deactivated).

### Phone Lock

The phone lock protects the phone against unauthorised use in the event of theft. It is not activated when you purchase the phone. You should, however, activate it as soon as possible and also change the factory-programmed security code of 0000 to any 3- to 8-digit personalised code.

There are two levels of locking the phone: **Full Lock** and **Autolock**.

If the **Full Lock** is activated, the message

'Phone locked' is displayed briefly, each time the phone is turned on. The message is followed by the prompt 'Enter lock code'. The user then has to enter a **security code** and press # (or YES) to be able to use the phone.

If the **Autolock** is activated, the message 'Phone locked' and the prompt 'Enter lock code' will not appear until a **different SIM card** is inserted in the phone. After the security code has been entered correctly, the phone can be used with **new SIM card**. The user will not be asked to enter the security code until the **original SIM card** or a **different SIM card** is inserted.

### To change the security code

```
ACCESS
Phone lock
Change code
```

Select 'Phone lock Change code' from the **ACCESS** menu and follow the same procedure as for changing the PIN code.

### To lock/unlock the phone

```
ACCESS
Phone lock
(Unlocked)
```

Select 'Phone lock' from the **ACCESS** menu. The current setting 'Full Lock', 'Autolock' or 'Unlocked' is shown between brackets.

Select the desired setting. Enter the security code (3-8 digits) and press # (or YES). 'PHONE LOCK' is displayed, together with the new setting.

### Call Barring

This service may not be available on all networks or may require a separate subscription.

The **Call Barring** service of the cellular network allows you to bar different types of outgoing and incoming calls to restrict the use of your phone.

You can bar:

- All outgoing calls – 'All outgoing calls'
- All outgoing international calls – 'All outgoing int calls'
- All outgoing international calls **except** to your home country – 'Int outgoing when roam'
- All incoming calls – 'All incoming calls'
- All incoming calls when you are abroad (when roaming) – 'All incoming when roam'

To ensure that a call bar is not changed by someone else, a **password**, which comes with your subscription, is necessary to activate or cancel a call bar.

**To activate, check the status or cancel a particular call bar**

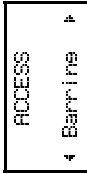

Select **'Barring'** from the **ACCESS** menu.

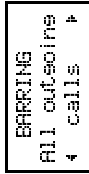

The first barring option is **'All outgoing calls'**. To choose another barring option, scroll with **▲/▼**.

Press **YES** to select the desired barring option. In this example we will choose **'All outgoing int(ernational) calls'**.

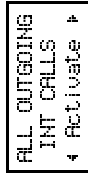

Select the desired option: **'Activate'**, **'Get status'** or **'Cancel'**.

Enter your password and then press # or YES. There may be a short delay before the network responds. In the meantime, the message **'Please wait'** is displayed. This is followed by a message which informs whether the call bar is activated or not.

*If you divert your incoming calls(refer to chapter 12. Diverting Incoming Calls) you cannot*

*activate some barring options. Likewise, if you bar calls, you cannot activate some call divert options.*

**To cancel ALL call bars**

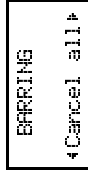

Select the **'Cancel all'** option.

Enter your **password** and press # (or YES).

The message **'Please wait'** appears, followed by a message that confirms that all call bars are cancelled.

**To change your password**

The password for the **Barring** service comes with your subscription. You can easily change the password as often as you like.

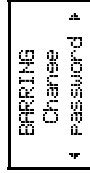

Select the **'Change password'** option.

Enter the **old** (the current) password and press # (or YES).

Enter the **new** password and then press # (or YES).

Enter the **new** password **again** and then press # (or YES).

The message **'Please wait'** appears, followed

by a message that confirms that the password has been changed.

**Locking the keypad**

You can lock the keypad so that unintentional key action has no effect if the phone is turned on.

An icon in the shape of a key (🔑) on the left in the middle line of the display informs you that the keypad is locked.

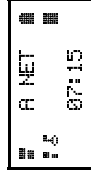

*Calls to the international emergency number 112 can be made when the keypad is locked.*

*If the phone's alarm sounds, you can turn it off by pressing any key.*

The keypad remains locked until you:

- answer an incoming call by pressing **YES**.
- You may also reject the call by pressing **NO**
- replace the battery
- unlock the keypad yourself

**Automatic keypad lock**

The **'Keypad lock'** function in the **SETTINGS** menu lets you choose **manual** or **automatic** keypad lock.

If you have chosen the **automatic** mode, the keypad is locked automatically 25 seconds after the last key was pressed.

### To lock the keypad manually

Scroll to the **KEYLOCK** menu with  $\blacktriangle/\blacktriangleright$ .

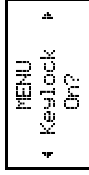

Then press **YES**.

### To unlock the keypad

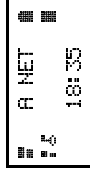

Press  $\blacktriangle$ ,

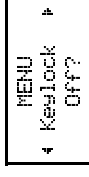

followed by **YES**.

## 11. Setting Time, Date and Alarm (CLOCK Menu)

The **CLOCK** menu lets you set the time of the day and today's date. It also lets you activate the alarm function.

### Clock (Time of Day)

The time is shown continuously in the bottom line of the display when the phone is in stand-by mode.

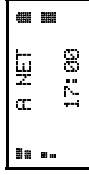

### To change the time format

The hours and minutes can be presented in either the 24-hour format or the 12-hour (a.m./p.m.) format.

Select '**Clock mode**' from the **CLOCK** menu.

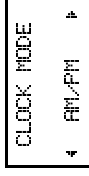

Choose the desired mode and press **YES**.

### To set the clock

Select '**Set Clock**' from the **CLOCK** menu.

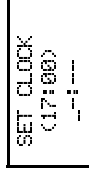

Enter the time, in hours and minutes, and press **YES**.

- If you wish to keep the minute digits, just enter the hour digits. You can also change the hour digits by pressing  $\blacktriangleright$  and  $\blacktriangle$ .

- If you have chosen the 12-hour format in the '**Clock mode**' function, you can change from a.m. to p.m., or vice versa, by pressing \* or #.

### Calendar (Today's Date)

You can have today's date presented in the middle line of the display when the phone is in stand-by mode.

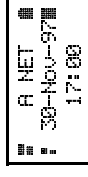

### To choose the date format

Select '**Date mode**' from the **CLOCK** menu. Scroll to the desired format, for example:

```
DATE MODE
# 30/11/96 #
```

and press YES.

**To set today's date**

Select 'Set Date'.

```
SET DATE
Enter year:
-
```

Enter the year (two digits) and press YES.  
Enter the month and the day in the same way.

**Alarm**

The phone has an alarm function. When it is activated, an icon in the shape of a bell (🔔) is shown prior to the time of day.

```
🔔 A NET 🔔
#19:00
```

The alarm will sound at the time set, even if the phone is turned off. The illumination of the keys and the display will flash, too. The sound level of the alarm depends on the setting of the ringing signal level.

```
Alarm
19:00
```

The alarm will sound for 60 seconds and it will be repeated every nine minutes if you do not turn it off. To turn it off, you can press any key.

```
Alarm
Turn off?
```

Press YES if you do not want the alarm to be repeated.

**To set the time and turn the alarm function on**

Select 'Set alarm' from the **CLOCK** menu and scroll to the 'New time' option.

```
SET ALARM
# New Time #
(00:00)
```

Press YES.

```
SET ALARM
(00:00)
--:--
```

*If you have chosen the a.m./p.m. format in the 'Clock mode' function, you can change from a.m. to p.m., or vice versa, by pressing \* or #.*  
Enter the time, in hours and minutes, for example 14:30, and then press YES.

```
CLOCK
#Set alarm #
(14:30)
```

If you wish to keep the minute digits, just enter the hour digits and press YES. You can also change the hour digits by pressing ➡ and ⬅.

**To turn the alarm function off**

```
CLOCK
#Set alarm #
(14:30)
```

Press YES. Scroll with ⬅/➡ until 'Off' appears.

```
SET ALARM
# Off #
(14:30)
```

Press YES.

```
CLOCK
#Set alarm #
(Off)
```

**To turn the alarm function on without changing the time of the alarm**

```
CLOCK
#Set alarm #
(Off)
```

Press YES. Scroll with ⬅/➡ until 'On' appears.



You may now:

- a. Enter the phone number to which you want your calls to be diverted, **including** the area code, and then press **YES**.
- b. Enter an **international** number. Press and hold down the **0** key to insert the international character “+”. Then enter the country code, the area code and the phone number. Note that a leading **0** in an area code must be omitted. Finally, press **YES**.

- c. Recall the number from the Phone Book. Press **↵** and then recall the number. Finally, press **YES**.

If you used the **ON busy** divert on an earlier occasion and then cancelled it, the phone number to which the calls were diverted will be suggested. To keep the number, just press **YES**. Otherwise, erase the number using the CLR key and enter the new number.

There may be a short delay before the network responds. In the meantime, the message **‘Please wait’** is displayed. This is followed by the message **‘On busy Divert ON’**, together with the phone number.

Incoming calls will now be diverted to this phone number when you are engaged in a call.

*If you bar calls (refer to Call Barring in chapter 9, Protecting the SIM Card and the Phone) you cannot activate some divert options. Like-*

*wise, if you divert calls, you cannot activate some barring options.*

As a reminder, the display will inform you about any activated call divert each time you turn the phone on.

### To check the status of a call divert

Select the desired call divert from the **DIVERT** menu.

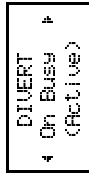

Press **YES** and scroll to the **‘Get status’** option.

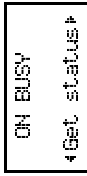

Press **YES** to check the status. The message **‘Please wait’** appears, followed by either the phone number and **‘Active’** if the call divert is activated, or **‘Off’** if it is not activated.

### To cancel a call divert

Select the desired call divert from the **DIVERT** menu

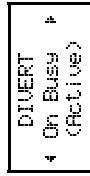

Press **YES** and scroll to the **‘Cancel’** option.

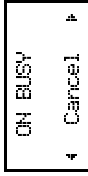

Press **YES** to cancel the call divert. The message **‘Please wait’** appears, followed by a message which informs you that the call divert has been cancelled.

### To cancel ALL call divers

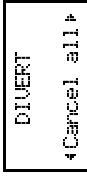

Select the **‘Cancel all’** option from the **DIVERT** menu.

The message **‘Please wait’** appears, followed by a message which informs you that all call divers have been cancelled.

### To review the status of ALL call divers

Select the **‘Check all’** option from the **DIVERT** menu.

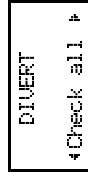

The message **‘Please wait’** appears, followed by information about all call divers, whether they are activated or not.

## 13. Using Other Networks (NETWORKS Menu)

When you are abroad, you may use other networks, provided your home network has an agreement that allows you to use the networks. This is called roaming.

When you turn the phone on, it normally selects its home network. If this is not within range, for example when you are abroad, you may use another network, provided your home network has an agreement which allows you use this network.

The NETWORKS menu includes a number of functions which you can use to determine how the phone searches for a network. You may also select a network yourself from those within range.

### To select a network

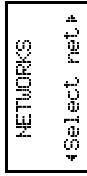

Select 'Select net' from the NETWORKS menu.

The message 'Please wait' is displayed briefly.

a. If the home network is within range and you are using it, its name is displayed with the message **Current**.

If you are using another network, the name of the home network is displayed with the message **Home**.

Instead of the full name of a country and a network, an abbreviation is displayed when you use the NETWORKS menu.

If you wish to see the full name of a network, press \*.

- b. If the home network is not within range, the name of another network is displayed with the message 'Current', 'Preferred', 'Available' or 'Forbidden'.
  - 'Current' means that the network is currently used.
  - 'Preferred' means that the name of the network is included in a list of preferred networks on your SIM card. Refer to the description of the **Edit List** function below.
  - 'Available' means that you are allowed to use the network.
  - 'Forbidden' means that you are not allowed to use the network. You can, however, make emergency calls. See also the next section, **List of Forbidden Networks**.

c. If no network is within range, the message 'No network' is displayed.

If more than one network is within range, the

name of the other networks can be displayed one by one by pressing **➤**.  
When the network you wish to use is displayed, press **YES** to select it.

### List of Forbidden Networks

The names of the forbidden networks are stored in a list on your SIM card. If such a network is in range, it will be omitted when the phone searches for a network (automatic search mode).

If the state of things changes, and your home network and a forbidden network have come to an agreement that allows you to use the forbidden network, you can select this network through the message 'Forbidden' is displayed. By doing so, you will delete the name of the network from the list of forbidden networks.

### To choose automatic or manual network search mode

Select 'Searchmode' from the NETWORKS menu. Then choose 'Auto' (automatic search mode) or 'Manual' (manual search mode).

### Automatic search mode

```
NETWORKS
↳Searchmode▶
  (Auto)
```

In the first place, the phone searches for its **home** network. If this is not available, the phone will search for another available network from those within range.

The **order of preference** in which the phone will select a network, in case the home network is not within range, is determined by a list of preferred networks on your SIM card.

### Manual search mode

```
NETWORKS
↳Searchmode▶
  (Manual)
```

The phone will select its **home** network in the first place and the network that was last used in the second place. If none of these networks is within range, the question '**Select network?**' appears.

To select a network, press YES. Then proceed as described above under **To select a network**.

### To create a list of preferred networks on your SIM card

If you wish, you can create a list which defines the order of preference in which the phone will select a network during automatic network se-

lection when the home network is not within range.

The number of networks that can be stored in the list depends on your SIM card.

The '**Edit List**' function lets you **review** the networks in the list, **add** networks to the list, **delete** networks from the list and **re-arrange** the order of the networks.

### To review the list of networks

```
NETWORKS
↳Edit list▶
```

To review the list, select '**Edit list**' from the **NETWORKS** menu. The message '**Please wait**' is displayed briefly.

```
EDIT LIST
AB CDEF *
↳ 1 ▶
```

The name of the **first** network is displayed. If a \* is also displayed, this indicates that the network is within range.

To see the *full name of a network*, press \*.

You can scroll through the other networks in the list with **↔/▶**.

### To add a network to the list

```
EDIT LIST
AB CDEF *
↳ 1 ▶
```

Scroll to the position where you wish to insert the network.

- If you scroll to the **first free** position, the question '**Add net?**' appears
  - If you scroll to a position that already is occupied, you must press YES and then scroll with **↔/▶** until '**Add net?**' appears.
- Press YES and then scroll with **↔/▶** until you find the desired network.
- If the *desired network does not appear*, press YES when the question **Other?** appears. Then enter the 3-digit country number and the 2-digit network number.

Finally, press YES to add the network to the list.

### To delete a network from the list

```
EDIT LIST
AB CDEF *
↳ 1 ▶
```

Scroll to the network you wish to delete and press YES.

Scroll until '**Erase**' appears.

Press YES to delete the network from the list.

**To re-arrange the order of the networks in the list**

```
EDIT LIST
AB CDEF *
4 1 1 4
```

Scroll to the network you wish to move and press YES.

'Move' is displayed. Press YES and then enter the new position within in the list.

**To start an automatic network search**

```
NETWORKS
4New Search
```

You can start an automatic network search at any time by selecting the 'Newsearch' function from the NETWORKS menu.

EN/IZT 126 1353 R/A

## 14. Sending DTMF Tones

You can use your phone to send DTMF (Dual Tone Multi Frequency) tones. This feature can be used for a variety of purposes, such as banking by phone or controlling an answering machine.

### Automatic DTMF

You can send DTMF tones during a call. You can send the characters 0 – 9, \*, and # as DTMF tones by pressing the corresponding keys.

### DTMF pause function

If you wish to send a code, for example your personal access number, it might be helpful to use the pause function. Before you make the call, you enter both the phone number and the code, separated by a **pause** character.

### To make a call and send a code

1. Enter the desired phone number.

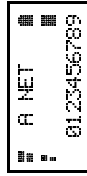

2. Select the **SPECIAL CHARACTERS** menu by pressing **➤**, followed by **YES**.

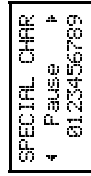

3. Enter a pause character by pressing **YES**. The letter **p** appears in the display.

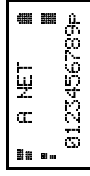

### Shortcut:

You can also enter a pause character by holding down **\***.

4. Enter the code you wish to send. The code can be any combination of the digits 0 – 9 and the characters \* and #.

5. Press **YES** to make the call.

When the call has been connected, the phone number disappears from the display. The code is sent automatically, character by character, after a delay of 3 seconds. The message '**Sending**' is displayed while the code is sent.

### Using several pauses

You can enter several pauses, for example:

PHONE.NO.p CODE1.p CODE2

When the call has been connected, the code, following the first pause character, will be sent

automatically after 3 seconds. To send the next code, press **YES**.

### Pre-programmed DTMF signalling

You can store a code in the phone book in the same way as you store a phone number. The code can be any combination of the characters 0 – 9, \* and #.

The maximum number of characters that you can store in the Card Memory depends on your SIM. In the Phone Memory you can store up to 80 characters.

### To send the code

1. Call the desired phone number and wait until the call has been connected.
2. Recall the code from the phone book.
3. Send the code by pressing **YES**.

The characters are sent one by one. In the meantime the message '**Sending**' is displayed.

### Alternative method

You can store both a phone number and a code, separated by a pause character in the phone book.

### To send the code:

1. Recall the phone number and the code from the phone book.

2. Press **YES** to make the call. When the call is connected, the code is sent automatically after 3 seconds.

## 15. Who Is Calling?

The *Calling Line Identification (CLI)* service allows you to see the caller's phone number in the display, giving you a chance to identify the caller. This service may not be available on all networks and may require a separate subscription.

### To receive a call

When an incoming call is received, the caller's number appears in the display. If the caller's number and name is stored in the phone book, the caller's name will be displayed too.

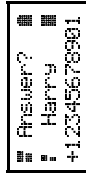

■ Answer? ■  
■ Harry ■  
■ +12345678901

Press **YES** to answer the call, or **NO** to reject it.

### Answered calls

The phone numbers of the last 5 answered calls are stored in a memory in the phone – the **Answered Numbers memory**.

### To review the phone numbers of answered calls

1. From the **PHONE BOOK** menu, select '**Received calls**'.

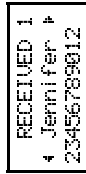

RECEIVED 1  
4 Jennifer ▸  
23456789012

The last caller's number and name (if the name is stored in the phone book) appear.

2. To see the other numbers (and names), scroll with **↔**.

### To call the number in the display

Press **YES**.

### To erase ALL numbers from memory

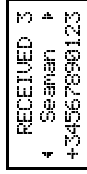

RECEIVED 3  
4 Seanan ▸  
+34567890123

1. Press and hold down **CLR**.



Erase  
all?

2. Press **YES**.



ERASED

## Unanswered calls

The phone numbers of the last 10 unanswered or rejected calls are stored in a memory in the phone – the **Missed Calls memory**.

### To review the phone numbers of unanswered calls

1. From the MAIL menu, select 'Missed calls'.

```
MISSED CALLS
4 14:51
+45678901243
```

The last caller's **number** or **name** (if the number is stored in the phone book) appears, together with the time when the call was received.

If no information about a caller's number was received, the number is replaced by the message '**Unidentified**'. If a caller wanted to withhold his or her number, the message reads '**Restricted**'.

2. To see the other unanswered calls, scroll with ➤.

```
MISSED CALLS
4 20-11-96
Unidentified
```

The day after a call has been received, the time of the call is replaced with the date. You can toggle between date and time by pressing \*.

### To call the number in the display

Press YES.

### To erase a "number" from the display

1. Press CLR.

```
MISSED CALLS
4 Erase?
Unidentified
```

2. Press YES.

### To hide your phone number when making a call

Normally, your phone number will be sent when you make calls. If you do not wish your number to be sent on a particular call, you can

use the '**Hide Id**' function in the **SPECIAL CHARACTERS** menu to suppress the number:

1. Enter the phone number you wish to call.
2. Press ➤, followed by YES. The **SPECIAL CHARACTERS** menu appears.
3. Scroll to '**Hide Id**' with ➤.
4. Press YES to make the call. A special code is inserted prior to the phone number.

### To send your phone number when making a call

If you subscribe to normally **withhold** your phone number when making calls, you can use the '**Send Id**' function in the **SPECIAL CHARACTERS** menu to send your phone number on a particular call:

1. Enter the phone number you wish to call.
2. Press ➤, followed by YES. The **SPECIAL CHARACTERS** menu display appears.
3. Scroll to '**Send Id**' with ➤.
4. Press YES to make the call. A special code is inserted prior to the phone number.

## 16. Handling Two Calls Simultaneously

The phone allows you to handle two calls simultaneously. This means that you may hold a call in progress and make or answer a second call, and then switch between them. This service may not be available on all networks.

### To activate the Call Waiting service

To be able to receive a second call, you must activate the **Call Waiting** service.

1. From the **ACCESS** menu, select the **'Call Waiting'** function .



CALL WAITING  
4 FUNCTION

2. Press **YES** to activate it.

There may be a short delay before the network responds. In the meantime, the message **'Please Wait'** is displayed. This is followed by the message **'Call Waiting ON'**.

You may turn the **Call Waiting** service off by selecting **'Cancel'**. **'Get status'** lets you check whether the service is activated or not.

### To make a second call while a call is in progress

#### Method 1

If anything else but the time is shown in the bottom line of the display, erase it with the **CLR** key.

1. Press **YES** to put the current call on hold. The message **'1 on hold'** (1st call on hold) appears.
2. Enter the number you wish to call, or recall it from the phone book, and press **YES**.

#### Method 2

Enter the number you wish to call and press **YES**. The message **'1 on hold'** appears.

### To receive a second call while engaged in a call

You will hear a tone in the ear piece and the message **'Call Wait'** appears in the display if the **'Call Waiting'** function is activated.

Do one of the following to:

- a. End the current call and accept the waiting call by pressing **NO**. The phone rings, and the question **'Answer?'** appears. Press **YES** to answer the waiting call.
- b. Put the current call on hold and accept the waiting call by pressing **YES**. The message **'1 on hold'** appears.
- c. Reject the waiting call and continue the current call by pressing **0**, followed by **YES**.

The waiting call is cleared. If the caller's network supports it, the caller will hear an engaged (busy) tone.

If **Divert On Busy** is activated, the waiting call is diverted to the number you have specified.

### To switch between two calls

When one call is active and the other is on hold, you can switch between them by pressing **YES**.

### To end the current call

End the current call by pressing **NO**.

The message **'Retrieve held call?'** appears.

Do one of the following:

- a. End the held call by pressing **NO**.
- b. Return to the held call by pressing **YES** within three seconds.

*If you do not press YES or NO within three seconds, the message 'Retrieve held call?' disappears from the display and the held call is ended automatically.*

### To receive a third call

Provided the **Call Waiting** function is activated, you may receive a third call when you are engaged in one call and have a second call on hold. You will hear a tone in the ear piece and the message '**Call Wait**' appears in the dis-

play. You may either accept the third call or reject it.

### To accept:

Only one call can be on hold at a time. If you wish to accept the third call, you must, end the first or the second call, or both. See **To end the current call** above.

- a. If you end the first or the second call, you can accept the waiting call (the third call) by pressing **YES**.
- b. If you end both calls, the phone rings and the question '**Answer?**' appears in the display. Press **YES** to answer the waiting call.

### To reject:

Press **0**, followed by **YES**.

The third call is cleared. Provided the caller's network supports this function, the caller will hear an engaged (busy) tone.

*If **Divert On Busy** is activated, the waiting call is diverted to the number you have specified.*

### Transferring a Call

If you have one **active** call and another call on **hold**, you can connect the two calls by pressing **4**, followed by **YES**. You are then disconnected from both calls.

## 17. Conference Calls

*The Conference Call service allows you to have a joint conversation with up to five people. You may put an individual or a group of conference members on hold while you add other people to the conference call. You may also put members of the conference on hold while you talk to an individual. The Conference Call service may not be available on all networks.*

### To initiate a conference call

1. Call the first person you wish to talk to in the conference call.
2. Put the person on **hold** by pressing **YES**.
3. Call the second person you wish to talk to.
4. Press **3**, followed by **YES** to **join** the two people to the conference.

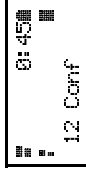
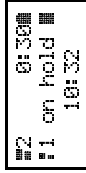

5. You can put the conference group **on hold** and then add a third member by repeating steps 2 and 4.

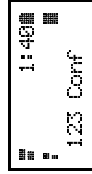

You can add up to **five** members using the same method.

### To have a private conversation with one of the members

If you wish to have a private conversation with one of the members, you can put the other mem-

bers **on hold** by pressing **2**, *the number of the member* and **YES**. For example, to talk to member No. 3, press **2 3 YES**.

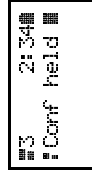

To **join** member No. 3 to the conference again, press **3 YES**.

### To release one of the members

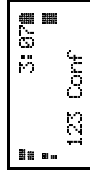

To release one of the members from the conference, press **1**, *the number of the member* and **YES**.

For example, to release member No. 1, press **1 1 YES**.

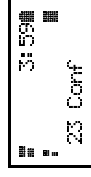

### To end the conference call

To end the conference call, press **NO**.

## 18. Answering Service

*The answering service of your network lets your callers leave a voice message when you cannot or do not wish to answer calls. This service may not be available on all networks and may require a separate subscription.*

The **VoiceMail** function of your phone makes it easy to can call your answering service to listen to recorded voice messages. Before you can use the **VoiceMail** function, you must activate it.

### To activate the VoiceMail function

From the **MAIL** menu, select the **'Set VoiceM'** function.

*If the number to your answering service can be retrieved from your SIM card, the number is shown between brackets. (This also applies if you have entered the number yourself at an earlier occasion and then turned the **VoiceMail** function off.)*

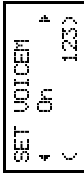

Press **YES** to activate the **Voicemail** function.  
If no number is shown between brackets,

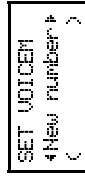

press **YES**.

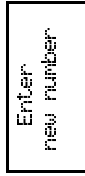

Enter the number. Press **YES** to activate the **Voicemail** function.

### To call your answering service

You can call your answering service at any time to listen to recorded messages.  
From the **MAIL** menu

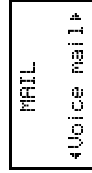

select **Voicemail** to call your answering service.  
Follow the instructions given to you.

Further information about the use of the answering service is found in the operating instructions supplied by your network operator.

### To turn the Voicemail function off or change the number to your answering service

From the **MAIL** menu, select the **SetVoiceM** function.

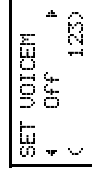

Press **YES** to turn the Voicemail function off, or scroll to '**New number**' and enter the number..

## 19. Sending and Receiving Text Messages (SMS)

*This option may not be available on all networks*

The **Short Message Service (SMS)** allows you to send and receive text messages. A message may contain up to 160 characters.

Text messages can be received when the phone is in stand-by mode, when you are engaged in a call, or when incoming calls are diverted to another phone number. If the phone is turned off, when somebody sends a message to you, you

will receive the message when you turn the phone on.

### Messages memory

When you receive a text message, you may read it at once. See **To receive a message** below.  
However, the message is automatically stored in the first free memory position in the Messages memory in the phone, allowing you to read it later on.

A letter icon, , is shown on the left in the bottom line of display, as a reminder that one or more unread messages has been received.

The Messages memory can hold up to 10 messages. When all memory positions are occupied, the oldest **read** message will be overwritten when a new message is received.  
If the Messages memory becomes full, new messages will automatically be stored in the SIM Card memory (see below). If the SIM card

memory becomes full, the letter icon, , starts blinking.

Messages remain in the Messages memory until you erase them or until you insert a different SIM card.

### SIM card memory

You can store important messages on your SIM card so that you can retrieve them regardless of which phone you use.

The number of messages that can be stored is SIM-dependent.

### To set phone for text messaging

If the phone number to your **Service Centre** of your network cannot be retrieved from your SIM card, you must specify the number yourself. Otherwise, you cannot reply to received messages or send your own messages.

1. From the **MAIL** menu, select the **'Send Messages'** function.

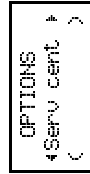

2. Press **YES** to select **'Options'**.

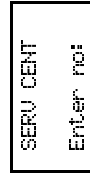

3. Enter the Service Centre number and then press **YES**. Press **CLR** to return to the standard mode.

Your phone is now ready to send and receive messages.

*You are only able to send and receive messages within your operator's network.*

### To receive a message

When you receive a message, a message signal sounds. You can decide whether tones or clicks will be heard with the **'Mail alert'** function in the **SETTINGS** menu. You can also turn the message signal off.

The indicator light on the top of the phone rapidly blinks green.

The display shows:

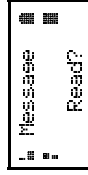

To read the message at once, press **YES**.

If you wish to read it later on, press **NO**.

### To read the message

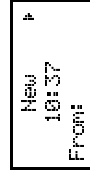

**'New'** stands for a new, unread, message. Press **YES** to read it.

You see the first three lines of the message.

Scroll forward through the message with **➤**, backward with **➤**. To go three lines forward, press the numeric key **3**.

After the last line has appeared, the question **'Reply?'** appears. If the caller wants you to reply, the last lines will read **'Reply Requested', 'Reply?'**, provided the network supports this.

You can now:

Press **➤** to scroll backward through the message.

Press **YES** to reply to the message.

Press **NO** if you do **not** want to reply.

### To reply to the message

If you answered **YES** to the question **Reply?**, the following is displayed:

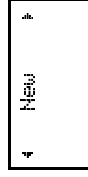

Press **YES**. An empty display appears. To enter your message, proceed as described under **Own Messages** later in this chapter.

### If you do not want to reply

If you answered **NO** to the question **Reply?**, the question **'Erase?'** appears.

You can now:

Press **YES** to **erase** the message from the Messages memory. You will then automatically come to the next message in the message list.

Press **NO** if you do **not** wish to erase the message. The message will remain in the Messages memory.

If you pressed **NO**, the question **'Store?'** appears.

Press **YES** to store the message in the SIM card memory. The message is erased from the Messages memory.

Press **NO** if you do **not** wish to store the message in the SIM card memory. The message remains in the Messages memory.

You can press **CLR** anywhere within the message to **erase** it. When the question **'Erase?'** appears, press **YES**.

### If you store a message in the SIM card memory

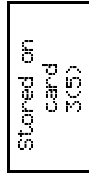

The display shows that the message is, for example, the third of five that is possible to store.

### To call a phone number in a message

Press **YES** when a **phone number** is found in the display to call the number direct.

After the number has been called, the message is considered as read and it remains in the Messages memory.

### To read stored messages

1. From the **MAIL** menu, scroll to **'Read messages'** to read messages stored in the Messages memory,

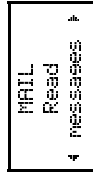

or to **'Card messages'** to read messages stored in the SIM card memory.

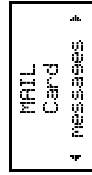

2 Press **YES** to select **'Read messages'** or **'Card messages'**.

3. Scroll with **▲/▼** until you find the message you are looking for and press **YES** to select it.

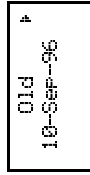

A read message is called **'Old'**, while an unread message is called **'New'**.

To read a message, proceed as described under **To receive a message** earlier in this chapter.

You may let a message remain in memory or erase it in the same way as described under **To receive a message** earlier in this chapter.

### Own messages

You can write, send, repeat, and change types of messages as follows.

#### To send messages

1. From the **MAIL** menu,

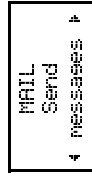

select **'Send messages'**.

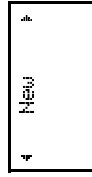

2. Press **YES**.

An empty display appears.

3. Key in your message.

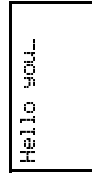

You can **backspace** the cursor with **▲** and then erase characters to the left of the cursor, or insert characters in the cursor's position.

4. When you are finished with your message, press **YES**.

Request  
reply?

Press **YES** if you wish the receiver to reply to the message. Press **NO** if you do not.

SEND  
MESSAGES  
Enter no?

5. Enter the receiver's phone number or recall it from the phone book. To access the **PHONE BOOK** menu, press **↵**.

6. Press **YES** to send the message or **NO** to store the message for later use.

If you decided to send the message later, the message is called '**Written**' instead of '**Sent**' when you access that message.

### To repeat a message when no answer

If a message cannot be delivered because the receiver cannot be reached, you can instruct your Service Centre to repeat a message for a certain amount of time: 1 hour, 12 hours, 1 day, 1 week or maximum (operator-dependent).

1. From the **MAIL** menu,

MAIL  
Send  
MESSAGES

select '**Send messages**'.

New

2. Scroll to '**Options**' and then press **YES**.

OPTIONS  
Valid per  
(1 day)

3. Press **YES**. Scroll to the desired repeat length and then press **YES**.

### To change message type

The phone is prepared for sending other types of message. Your Service Centre of your network may offer the facility to convert a text message into a format (fax, telex, voice, etc) that suits the equipment that receives the message.

Consult your Service Centre for further information about the formats types you can use.

1. Select '**Options**' as described above and then scroll to **Message type**.

OPTIONS  
Mes type  
(Standard)

'**Standard**' stands for an ordinary text message (SMS).

2. Press **YES**. Scroll to the desired message type (the format) and then press **YES**.

## 20. Using Area Information (AI)

*This feature may not be available on all networks*

The ordinary Short Message Service can be said to be a personal service, with messages specifically and exclusively directed to you. The **Area Information (AI)** is another, impersonal, type of text message which is sent to all subscribers in a certain cell of a network at the same time. The information may be a local road report or a local taxi phone number.

### To turn area information on or off

You can turn the AI presentation on/off with the 'Area info' function in the MAIL menu.

```
MAIL
Area info
(Off)
```

1. Press **YES** to select the 'Area info' function.
2. Scroll with  $\blacktriangle/\blacktriangleright$  to 'On' or 'Off' depending on whether you wish AI messages to be presented in the display or not.
3. Press **YES**.

### To decide which types of AI message you wish to receive

Each type of AI message is identified by a 3-digit code. At present, the following message types exist:

#### Code AI Message Type

- 000 Index
- 010 Flashes
- 020 Hospitals
- 022 Doctors
- 024 Pharmacy
- 030 Long-distance road reports
- 032 Local road reports
- 034 Taxis
- 040 Weather
- 050 District (base station identity)
- 052 Network information
- 054 Operator services
- 056 Directory enquiries (national)
- 057 Directory enquiries (international)
- 058 Customer care (national)
- 059 Customer care (international)

Refer to the information supplied by your network operator, for information about the AI services you can use.

### AI message list

You can decide which types of AI message you wish to receive. The phone's 'Area Info' list can hold up to 19 codes.

### To insert a code

Provided you have turned on the presentation of AI messages, you can access the 'Area Info' list from the MAIL menu.

```
MAIL
Area info
(On)
```

1. Press **YES** to select the 'Area info' function.
2. If necessary, scroll with  $\blacktriangle/\blacktriangleright$  to 'Edit List' and then press **YES**.

```
EDIT LIST
4 1 000
```

3. The digit to the left indicates the position in the list. You can scroll forward and backward through the list with the  $\blacktriangle/\blacktriangleright$ .
3. To insert a code, scroll to the first empty location with  $\blacktriangleright$  and press **YES**.
4. Enter the new code. (You only need to enter 40 for code 040, since the phone will add the leading zero automatically.)

### To erase or replace a code

If you wish to **erase** a code or **replace** a code, scroll through the list with **↔** until you find it and then press **YES**. The question **'Erase?'** appears.

- To **erase** the code, press **YES**.
- To **replace** the code, press **↔**, followed by **YES**. Enter the new code and press **YES**.

### To receive area information

An **AI** message is presented immediately, unless you are engaged in a call.

An incoming call always interrupts the presentation of an **AI** message. When the call is fin-

ished, the **AI** presentation continues until completed.

### To review received messages

The last message received of the type, specified by the code in positions 1 and 2 in the **'Area Info'** list, are stored in the phone.

You can read these messages with the **'Area Messages'** function in the **MAIL** menu.

```
MAIL
Area
4 MESSAGES
```

- Press **YES** to select it.

```
< 1 022>
doctor doctor
r doctor doc
```

- You can scroll from one message to other with **↔**.

```
< 2 040>
weather weat
her weather
```

- To select a message, press **YES**.
- To read a message, proceed in the same way as you do when you read a text message of the **SMS** type.

## 21. Two Line Service

Two voice lines with different phone numbers, Line 1 and Line 2, may be assigned to your phone. The ability to receive and send text messages (SMS) is, however, only available on Line 1. The Two Line service may not be available on all networks and may require a separate subscription.

### To select a line

If you have the Two Line service, you can press **↵** to reach a particular menu which lets you select Line 1

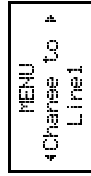

or Line 2

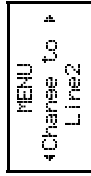

by pressing YES.

### Shortcut:

Instead of accessing the menu system, you can press and hold down the **1** or **2** key to change line, provided the phone is in standby mode. If you have entered digits into the bottom line of

### Different settings for each line

You can have different settings for each line, for example the tone of the ringing signal, call diverts, call bars and call waiting function.

The call time meters in the INFO menu show the call times (call costs) for the line currently selected.

### To personalise the names of the two lines

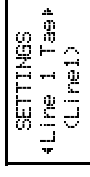

In the SETTINGS menu there is a function, Line 1 Tag or Line 2 Tag, depending on the line currently selected, that lets you give each line a name. Twelve characters can be entered at the most.

the display, press CLR to erase before pressing the **1** or **2** key.

The line selected is indicated as 'L1' or 'L2' on the left in the bottom line of the display.

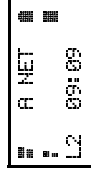

From now on, all outgoing calls are made on the line selected. You can, however, be called on both lines.

When you are called, the question 'Answer?' is replaced by 'Line1?' or 'Line2?' depending on the line currently selected.

If you are already engaged in a call on one line, you must end it to answer a call on the other line.

## 22. Knowing the Call Time/Call Cost

This chapter describes the **INFO** menu and its functions.

During an **outgoing** call, the call time is shown in the display.

```
SETTINGS
↓Call info ↓
( Time: Out. )
```

With the **'Call info'** function in the **SETTINGS** menu you can have the time displayed for **all** calls, both incoming and outgoing, **'Time: All'**.

You can also have the **call cost** or the number of **call units** displayed, **'Cost'**, provided your network and your SIM card support this feature.

### To check the time or cost of the last call

Later on, you can check the call time/cost of the last incoming (or outgoing) call with the **'Last call'** in the **INFO** menu.

Select the **INFO** menu.

```
INFO
↓Last call ↓
3:12
```

Depending on the setting in the **'Call Info'** function in the **SETTINGS** menu, you can check:

a. the elapsed time of the last **outgoing** call in (hours,) minutes and seconds

b. the elapsed time of the last **incoming or outgoing** call in (hours,) minutes and seconds, provided you have chosen **'Time: All'** in the **'Call Info'** function in the **SETTINGS** menu

c. the **cost** (or the number of **call units**) of the last incoming or outgoing call, provided you have subscribed to this feature and chosen **'Cost'** in the **'Call Info'** function in the **SETTINGS** menu

### To check the total call time or call cost

Select the **INFO** menu and scroll to **'Tot calls'**:

```
INFO
↓Tot calls ↓
2:30:25
```

Depending on the setting in the **'Call Info'** function in the **SETTINGS** menu:

- a. the elapsed time of all **outgoing** calls in (hours,) minutes and seconds
- b. the elapsed time of all **incoming and outgoing** calls in (hours,) in minutes and seconds

c. the **cost** (or the number of **call units**) of all incoming and outgoing calls

### To reset the total call time/cost meter

```
INFO
↓Tot calls ↓
2:30:25
```

Press **YES**.

```
TOT CALLS
Reset?
```

Press **YES** to reset the meter.

```
INFO
↓Tot calls ↓
0:00
```

**If you have chosen the call cost option**

You must enter the **PIN2** code to reset the meter.

### To determine the call cost

This function only appears if you have selected the **'Cost'** option in the **'Call Info'** function in

the **SETTINGS menu**. It is a prerequisite that your SIM card allows the call cost to be displayed.

Select **'Price'** from the **INFO** menu

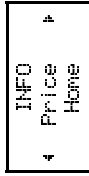

**'Home'** means that the number of **call units** will be displayed during a call, and in the **'Last call'** and **'Tot calls'** functions.

The **'Price'** function lets you enter and vary the price per call unit. The price entered will be stored on the SIM card.

**To enter the price per call unit**

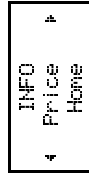

Press **YES**.

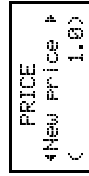

Press **YES**.

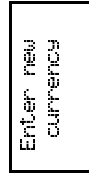

Enter the currency with the numeric keys, for example **GBP** for Pounds Sterling, and press **YES**.

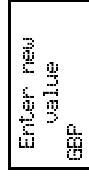

Enter the price per call unit, for example **0.25**, and press **YES**. To enter the decimal point, press \* or #.

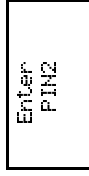

Enter the **PIN2** code and press # (or **YES**).

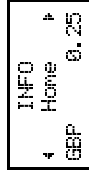

**To revert to displaying call units or change the price**

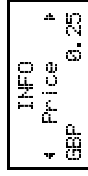

Press **YES**.

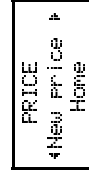

- a. To revert to displaying call units, press **YES**.
- b. To change the price, press **➤**.

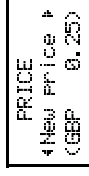

Proceed as described above under **To enter the price per call unit**. If you wish to keep the selected currency, just press **YES** when the prompt **'Enter new currency'** is displayed.

### Specifying a total amount of money that can be used for making calls

Provided both your network and your SIM card support this feature, you can enter a total amount of money that can be used to for making calls. After a call has been made, the call's cost will be deducted from this amount. When the amount has reached zero, no more calls can be made.

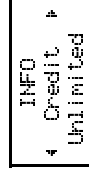

Select **'Credit'** from the **INFO** menu

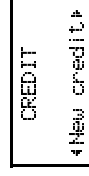

and press **YES**.

New Credit  
GEF

Enter the amount, for example 30 pounds, and press YES. Then enter the PIN2 code and press # (or YES).

## 23. Restricted Usage with Fixed Numbers

*Fixed Dialling is a method of restricting outgoing calls. It requires a SIM card that can allow fixed numbers to be stored. The fixed numbers are protected by the PIN2 code.*

The Fixed Dialling function allows calls to be made only to fixed numbers stored on the SIM card. If an attempt is made to call other numbers, the message **'Number not permitted'** appears in the display.

It is possible to store **partial** numbers, for example an area code, or an area code followed by the first digits common to several numbers.

Storing 0123456 allows calls to be made to 012345600 and 012345625.

Also numbers beginning with the international "+" character and country code can be stored, allowing calls to be made from abroad.

Numbers including **question marks** (?) can be stored. For example, storing 0123456?0 allows calls to be made to 0123456710 and 0123456790. To enter a **question mark**, hold down the # key.

Scroll to **'On'** with / and press YES.

ACCESS  
Fixed dial #  
(Off)

### Canceling the Fixed Dialling Function.

Proceed as described above but scroll to **'Off'** after you have entered the PIN2 code.

### Activating the Fixed Dialling function

ACCESS  
Fixed dial #  
(Off)

Select **'Fixed dial'** from the ACCESS menu. Enter the PIN2 code and press # or (YES).

FIXED DIAL  
Off #

### Storing fixed numbers

PHONE BOOK  
Fixed  
Numbers #

Select **'Fixed numbers'** from the PHONE BOOK menu.

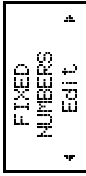

Scroll to 'Store' with **↔** and press **YES**. Enter the **PIN2** code and press **#** or **(YES)**.



Enter the name (optional) and the fixed number in the same way as you would when you store

an ordinary phone number. Refer to the description of the 'Store' function in chapter 8. **Using the Phone Book.**

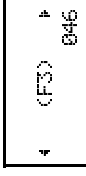

Press **YES**. After you have entered the **PIN2** code, you can change the position number, the name or the fixed number in the same way as you would do with an ordinary phone number. Refer to the description of the 'Edit' function in chapter 8. **Using the Phone Book.**

### To change a stored number

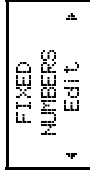

Select 'Edit' and scroll to the desired fixed number.

## 24. Data Menus

*The phone can be used with the Ericsson Mobile Office kit. This links the phone with a desktop or laptop PC, allowing you to use data communication and fax services from the PC.*

The 'Data menus' function in the **SETTINGS** menu lets you turn two data menus on.

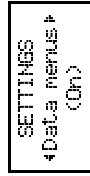

The one menu, **SPEECH THEN FAX**, will appear before the **INFO** menu when you scroll

with the **↔** key. The other menu, **NEXT CALL TYPE**, will appear after the **INFO** menu.

Refer to the description of the **Mobile Office** kit for further information about the use of the two data menus.

If you wish to **divert** incoming calls, you can divert phone calls, fax calls and data calls to different numbers in the **DIVERT** menu.

You can set different ringing signal tones for incoming phone, fax and data calls in the 'Ring type' function in the **SETTINGS** menu.

## 25. Using the Phone's Built-In Calculator

The calculator supports the four fundamental rules of arithmetic and percentages.

### To make a calculation

In this example we will divide 134 by 32. Scroll to the **CALCULATOR** menu

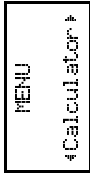

and press **YES**.

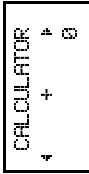

Enter **134**.

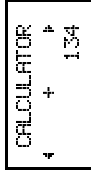

Scroll with **left/right arrow** to the division sign (**/**), and press **YES**.

Enter **32**.

Scroll with **left/right arrow** to the equal sign (**=**), and press **YES** for the result.

### To enter the decimal point

Press **\***.

### Shortcut:

Multiplying: Press **\*** twice.

Equal sign: Press **#**

## 26. Composing Your Own Ringing Signal

This chapter describes how you can record your own ring signal.

### About the phone's note system

Your phone has the capability to handle a range of tones spreading over two octaves.

Look in the table on the following page to understand which notes and other notation corre-

sponds to which keys. The figure on the following explains which key goes with which note on the keypad.

If you **hold down** a key, you make the note long.

### Simple melody

The simple melody is *Do-Re-Me*. This song corresponds to the C, D, and E tones on a music scale.

1. Select **'EditMelody'** from the **SETTINGS** menu. To erase characters from the bottom line of the display, use the **CLR** key. The bottom line of the display should now look like this.

-

2. Press the **1** key. The display will now show a **c**.
3. Press the **2** key. The display now looks like this:

c d \_

4. Press the **3** key. The display should now look like this:

c d e \_

5. Press **YES** to test the melody. The phone plays the melody and asks you if you want to save it.
6. Press **YES** to save the melody as an alternative in the **'Ring type'** function in the **SETTINGS** menu.

#### List of musical notation

Press this:	To:
<b>1-9</b>	insert notes, where 1 gives a C and 9 a high D.
<b>#</b>	increase or decrease the pitch in half tone steps. Press once to sharp (#), twice to flat (b), three times to get the normal pitch.
<b>*</b>	insert a short pause (1/8).
<b>←</b> <b>→</b>	scroll within the melody. Press and hold to get to the beginning or end of the melody.
<b>0</b>	get either a higher or a lower octave for the note you have inserted. You know it is higher as a plus sign is added in front of the note name.
<b>CLR</b>	erase the note to the left of the cursor. If you press and hold <b>CLR</b> , the whole melody is erased.

ON/OFF

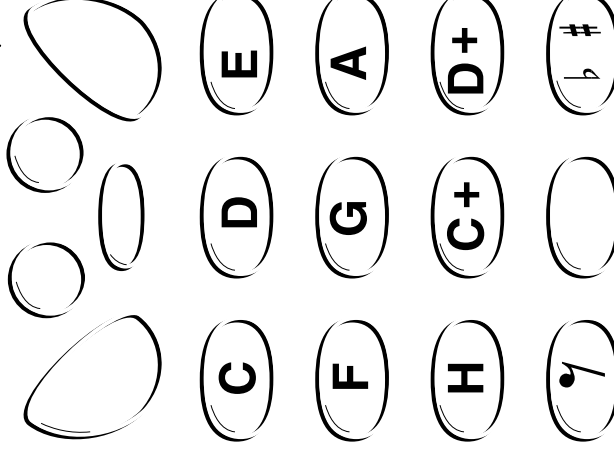

## 27. Problems You Can Solve

This chapter lists some simple things you should check before calling for service personnel. This could save the cost of unnecessary service.

### The phone does not come on

#### Handheld phone:

Recharge or replace the battery.

#### Handfree phone in a vehicle:

If the phone comes on, but not the handsfree equipment, ensure that the phone is properly inserted in its holder.

Check the fuse. The fuse holder is fitted to the battery cable, near the vehicle's battery.

### Phone locked is displayed, followed by the prompt Enter lock code

Phone locked

Enter lock code

The phone is locked to prevent unauthorised use.

#### To unlock the phone

Enter your personal 3- to 8-digit security code and press # (or YES).

#### If you have forgotten your security code

Contact your dealer. The only way to unlock the phone is through using your security code. Be aware that it, for security reasons, may take some time to solve the problem.

### Insert card is displayed

Insert card

No SIM card is inserted in the phone. Turn to chapter 1. **The Phone** for the procedure of inserting the SIM card.

### Wrong PIN or Wrong PIN2 is displayed

Wrong PIN

Wrong PIN2

The PIN or the PIN2 code has been entered incorrectly.

This message is followed by the prompt 'Enter PIN' or 'Enter PIN2'.

Enter the PIN or PIN2 code correctly and press # (or YES).

### Card blocked. Unblock? is displayed

Card blocked Unblock?

This message appears if the PIN code has been entered incorrectly three times in succession.

#### To unblock the SIM card

Press YES.

Enter code to unblock

Enter your **personal unblocking key (PUK)** and press #. You obtain the PUK from your network operator or service provider when you purchase your SIM.

Enter  
new PIN

Enter the **PIN** code and press #. You can either enter the current PIN, or a new one.

Repeat  
new PIN

Enter the **PIN** code again and press #. If you entered both the unblocking key and the PIN code correctly, the message 'New PIN' appears.

#### **Alternate method to unblock the SIM card**

Card  
Blocked  
Unblock?

To unblock the SIM card, enter the following sequence:

\* \* 0 5 \* **UNBLOCK KEY** \* **NEW PIN** \*  
NEW PIN #

#### **BLOCKED. Contact card provider is displayed**

BLOCKED  
Contact card  
Provider

EN/LZT 126 1353 R1A

The SIM card is permanently blocked after the unblocking code has been entered incorrectly ten times in succession. Contact your network operator or service provider.

#### **Enter PUK2 is displayed**

Enter  
PUK2

The PIN2 code has been entered incorrectly three times in succession.

Enter your **personal unblocking key 2 (PUK2)** and press #. You obtain your **PUK2** from your network operator or service provider.

Enter  
new PIN2

Enter the **PIN2** code and press #. You can either enter the current **PIN2** code, or a new one.

Repeat  
new PIN2

Enter the **PIN2** code again and press #.

If you entered both the unblocking key and the PIN2 code correctly, the message **New PIN** appears.

#### **Emergency calls only is displayed**

! Emergency  
! calls only  
09:58

A network is in range but you are not allowed to use this network.

You may, however, call the emergency number 112.

#### **No network is displayed**

! No network  
! 13:10

This indicates that no network is in range. The reason for this is either:

- You are in an area which is not covered by a network.
- The received signal is too weak. You have to move to obtain a sufficiently strong signal.

#### **Handsfree phone in a vehicle:**

Ensure that the phone is properly inserted in its holder.

Check the external antenna and its connection.

**A key symbol is displayed in the middle line of the display**



The keypad is locked to prevent unintentional key action.

**To unlock the keypad**

Press **★**, followed by **YES**.

**You have chosen a wrong language in the display**

To return to English text, enter the following sequence

**\*#0000#**

**Indicator light blinks red**

This indicates that the battery is becoming exhausted and soon needs recharging or replacing.

|

|

—

—

—

—

|

|

|

|

—

—

—

—

|

|