

# Panasonic

AUTOMATIC TELEPHONE  
ANSWERING SYSTEM

*Easa-Phone*

MODEL NO. **KX-T5206E**

## Operating Instructions

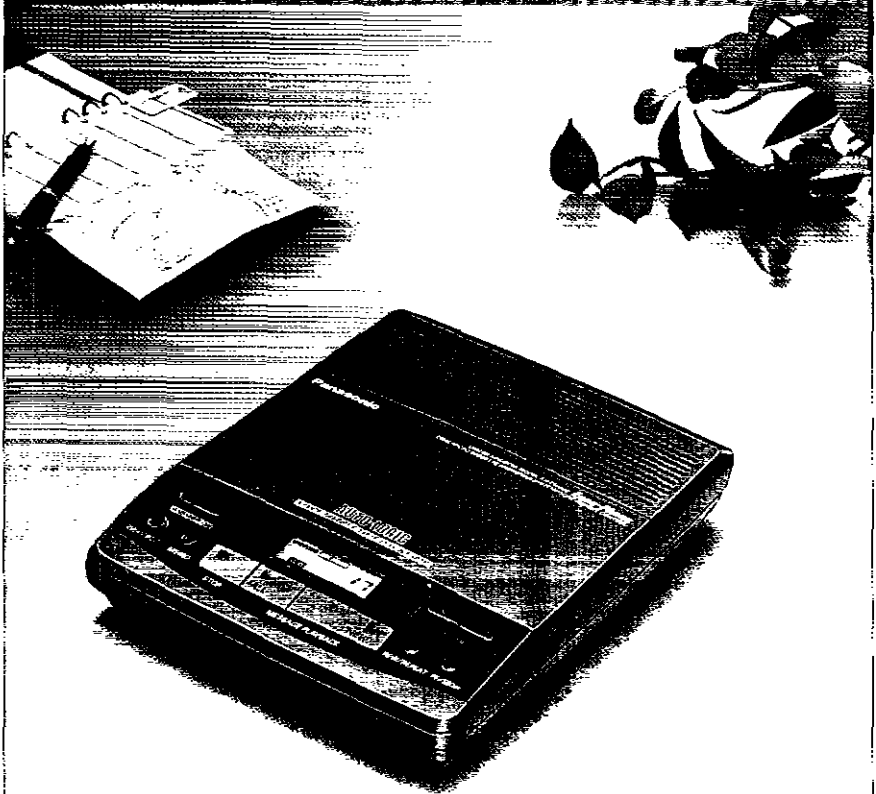

Please read before use.

**AUTO-LOGIC**

# Important information

**APPROVED** for connection to telecommunication systems specified in the instructions for use subject to the conditions set out in them.

S/1010/3/R/503137

Do not connect the AC adaptor to any AC outlet other than the standard AC 240 V, 50 Hz.

- Outlet voltage DC 13.5 V, 400 mA
- The apparatus is approved for use with the KX-A11BE or KX-A11DBE power supply.
- CAUTION: Do not remove cover. Live parts inside.

## **Ringer Equivalence Number (REN):**

This relates to the performance of the apparatus when used in combination with other items of apparatus. It enables the calculation of the maximum number of items of apparatus that may be connected simultaneously to the line by summing the REN values of each item. A BT supplied instrument has a REN value of 1 unless otherwise marked. A maximum REN value of 4 should not be exceeded. The REN value of this apparatus is 1.

## **Method of connection**

This is connected to the exchange line or PABX/PMBX (Private Automatic/Manual Branch Exchange) extension by the new standard British Telecom plug and socket.

Arrangements for provision of this type of termination can be made through the nearest British Telecom Sales Office. The apparatus may be connected to the following types of installation. The apparatus has been approved for use under the following conditions:

- a) For connection to the public switched telephone network (PSTN) and compatible PBX (Private Branch Exchange), which use LD signalling and MF signalling. (Please consult your supplier for an up to date list of compatible PBX's.)
- b) The apparatus can be used on extension sockets connected to a direct exchange line (D.E.L.).
- c) This apparatus is suitable for connection to the telecommunication system directly or via compatible private branch exchange as an extension. The supplier of the apparatus should be consulted for an up to date list of PBX's with which the apparatus is compatible.

- d) *This apparatus must not be connected in the following manner:*
- 1) *As an extension to a pay phone*
  - 2) *As a party line with shared service*

It cannot be guaranteed that the apparatus will operate under all possible conditions of connection to compatible PBX's.

- *This apparatus is suitable for connection to a PBX with or without initial proceed indication.*
- *This apparatus is suitable for connection to a PBX with or without secondary proceed indication.*

This apparatus is suitable for connection to a Relevant Branch System that is connected to one or more PSTN line, as defined in BS 6789 Section 6.1 Clause 2.4.

This apparatus has been approved for the use of the following facilities:

- 1) *3-step caller's recording time selector:  
VOX/1 MIN/GREETING ONLY*
- 2) *3-step ring selector:  
2/6/AUTO*
- 3) *Answering and recording system*
- 4) *Auto disconnect*
- 5) *DTMF tone remote control system*
- 6) *Monitoring a telephone call*
- 7) *Series Connection*

Any other usage will invalidate the approval of the apparatus if as a result, it then ceases to conform to the standards against which approval was granted.

A voltage drop of 0.3 volts at 40 mA will be introduced between the telephone socket and the PSTN.

*Any cases of difficulty should be referred in the first instance to the supplier of the apparatus.*

**NOTE:**

*If you experience any problems with the normal use of your apparatus, you should unplug it from the telephone outlet and connect a known working telephone in its place. If the known working telephone still gives problems, then call British Telecom Engineers. If it operates properly, then the problem is likely to be a fault in your apparatus. In this case, contact your supplier for advice. British Telecom will charge you if they attend a service call that is not due to apparatus supplied by them.*

# Included with this unit \_\_\_\_\_

AC Adaptor ..... one  
(p. 11)

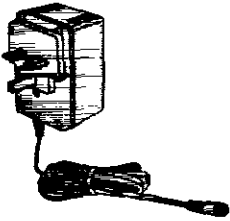

Greeting Message Tape  
(MC-10) ..... one  
(p. 10)

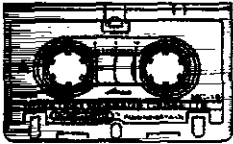

Incoming Message Tape  
(MC-30) ..... one  
(p. 10)

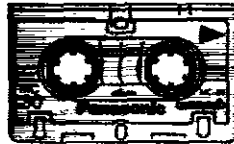

# Contents

---

Important information .....	2
Included with this unit .....	4
Location of controls .....	7
Display .....	9
Setting up the unit .....	10
Inserting the cassette tapes .....	10
Connection .....	11
Setting the selector switches .....	12
Time and day adjustment .....	14
Recording a personal greeting message .....	16
Pre-recorded greeting messages .....	18
Checking the greeting message .....	19
Adjusting the VOLUME control .....	19
Setting the greeting monitor function .....	21
Automatic answering operation .....	22
Setting the unit to answer calls .....	23
Selecting the greeting message .....	23
Listening to the recorded messages .....	24
Listening to new messages only .....	25
Listening to all the recorded messages .....	25
Saving some old messages .....	27
Resetting the incoming message tape .....	28
Erasing the recorded messages .....	28

Recording your own message . . . . .	29
Recording a telephone conversation . . . . .	30
Monitoring incoming calls . . . . .	31
Remote operation from a touch tone phone . . . . .	32
Setting the remote code number . . . . .	32
Going into voice menu . . . . .	33
List of the voice menu . . . . .	34
Direct remote operation (Basic) . . . . .	36
Direct remote operation (Advanced) . . . . .	38
Troubleshooting guide . . . . .	43
Maintenance . . . . .	44
Safety instructions . . . . .	46

# Location of controls

---

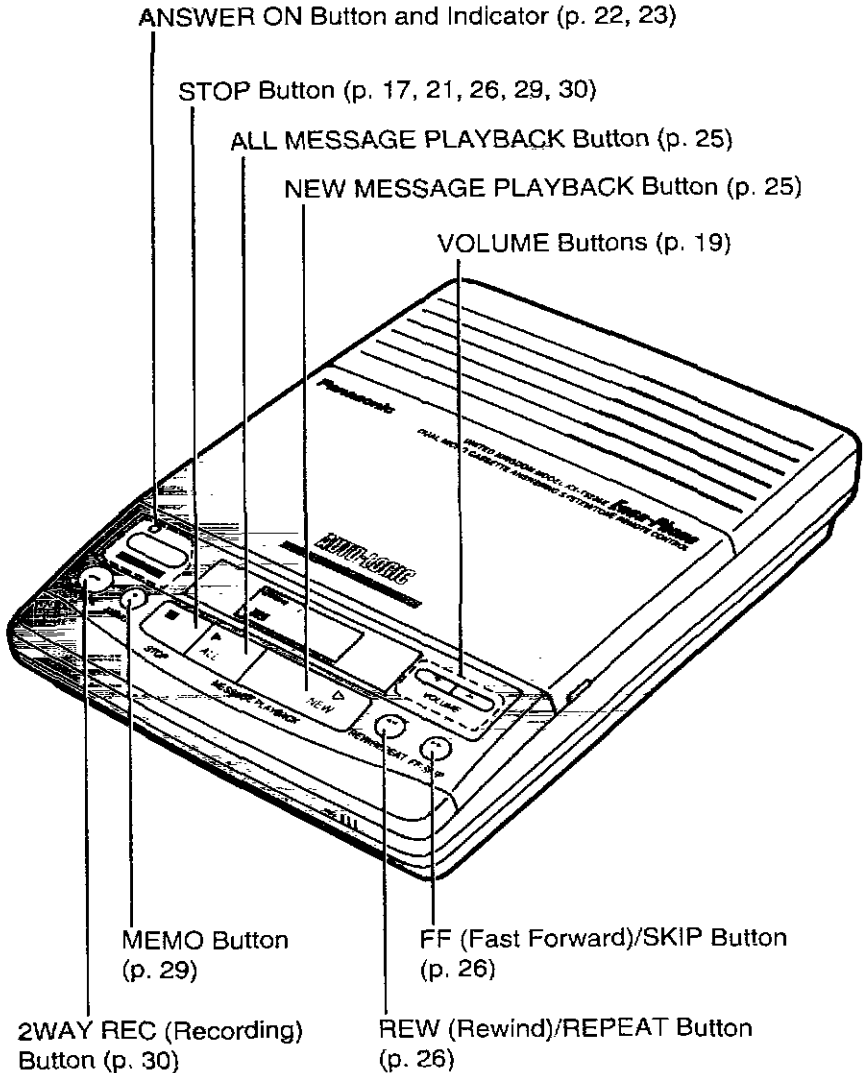

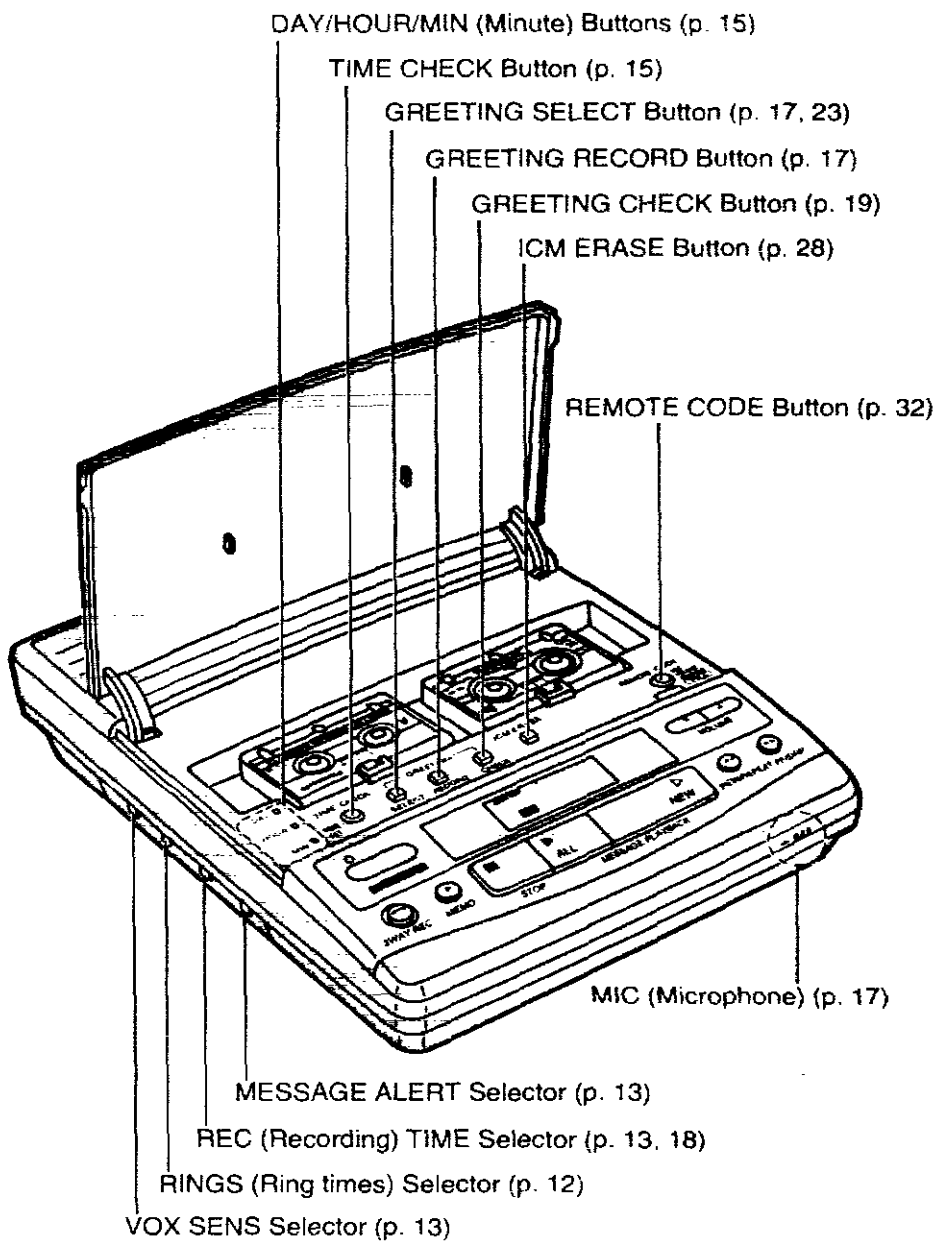

DAY/HOUR/MIN (Minute) Buttons (p. 15)

TIME CHECK Button (p. 15)

GREETING SELECT Button (p. 17, 23)

GREETING RECORD Button (p. 17)

GREETING CHECK Button (p. 19)

ICM ERASE Button (p. 28)

REMOTE CODE Button (p. 32)

MIC (Microphone) (p. 17)

MESSAGE ALERT Selector (p. 13)

REC (Recording) TIME Selector (p. 13, 18)

RINGS (Ring times) Selector (p. 12)

VOX SENS Selector (p. 13)

# Display

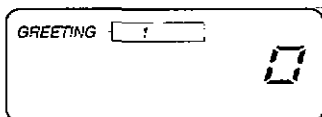

First greeting message is selected (pages 17 and 23). No messages have been recorded.

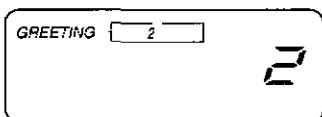

Second greeting message is selected (pages 17 and 23). 2 messages have been recorded.

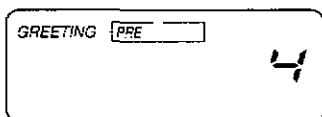

Pre-recorded greeting message is selected (pages 18 and 23). 4 messages have been recorded.



First greeting message is selected and the REC TIME selector is in the GREETING ONLY position (pages 13 and 18).

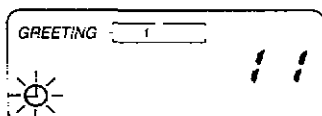

The clock in the unit is not adjusted. Program it before use (page 14).

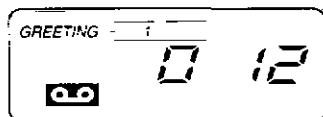

The first greeting is being recorded. The call counter counts the recording duration (page 17).

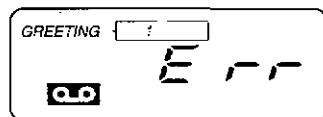

When recording the first greeting message, it results in failure.

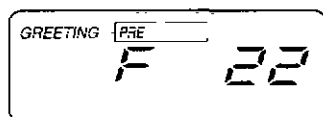

The incoming tape is full. ("22" represents the number of messages recorded, for example).

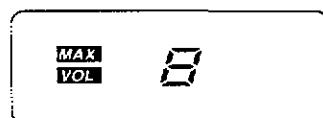

You are adjusting the volume. The number shows the current volume level (page 19). When the volume level is set to maximum (8).

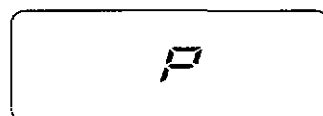

The unit is in the programming mode (page 21).

# Setting up the unit

## Inserting the cassette tapes

Remove the stopper from the micro cassette tapes.

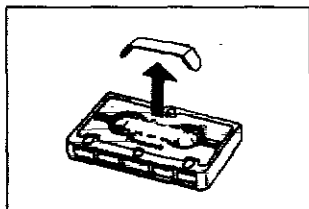

Open the cassette compartment lid.

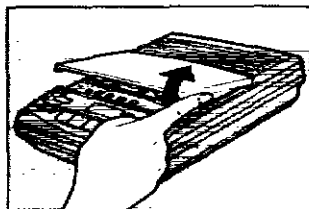

Insert the cassette tapes with the full reel to the left.

Greeting Message Tape (MC-10)

Incoming Message Tape (MC-30)

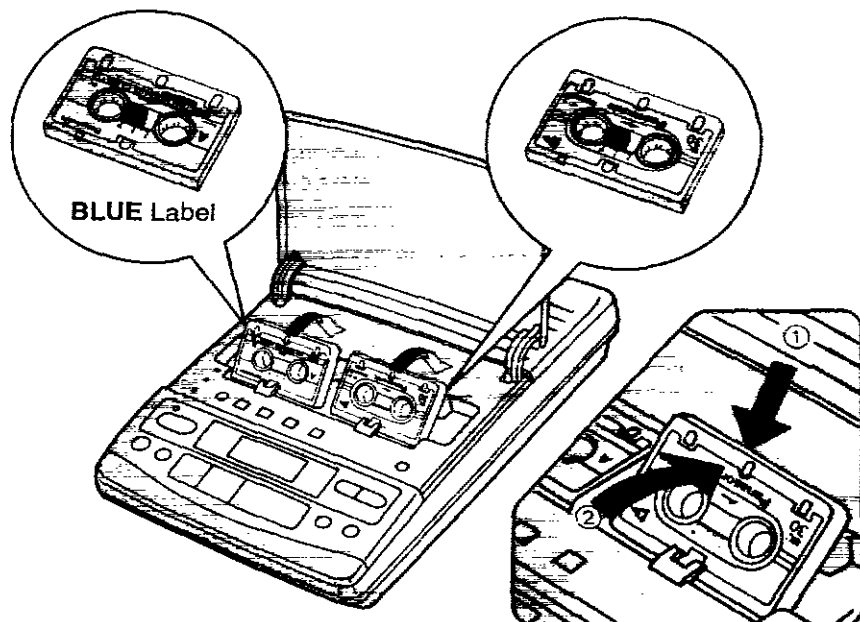

# Connection

## CONNECTION OF POWER SUPPLY

This apparatus is intended for use when powered by the KX-A11BE or KX-A11DBE. Using other power supplies will invalidate any approval given to this apparatus.

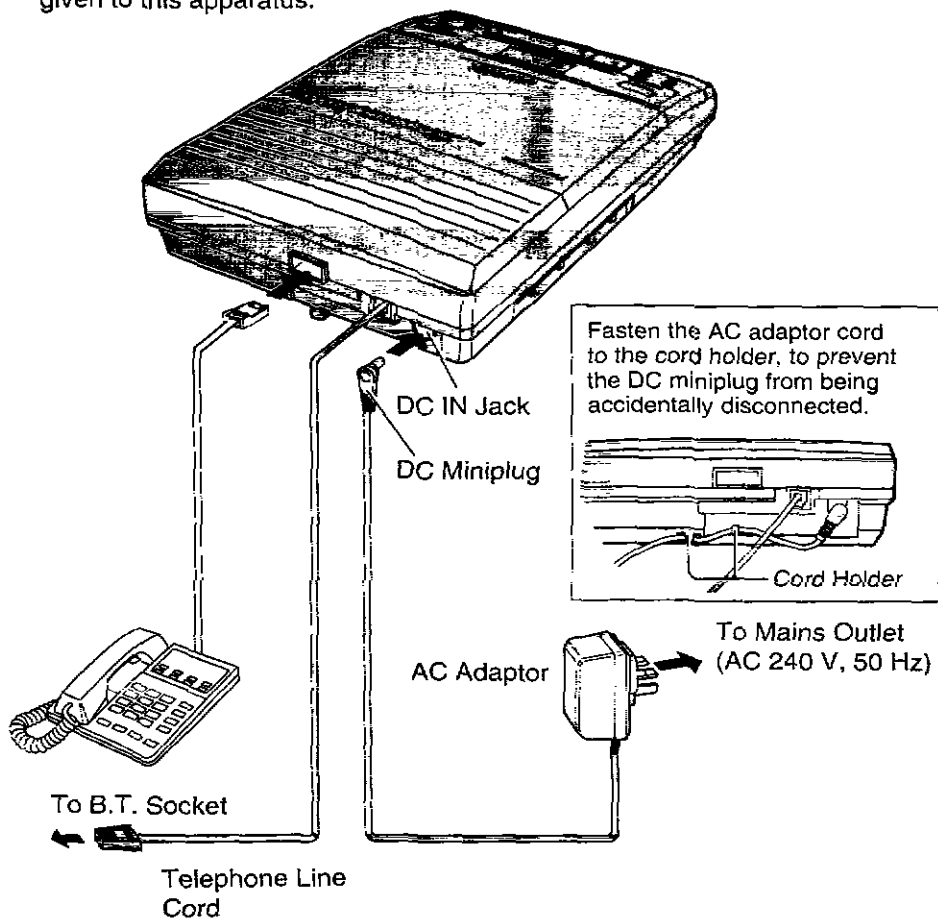

### Notes:

- USE ONLY Panasonic AC ADAPTOR KX-A11BE or KX-A11DBE. The adaptor must remain connected at all times.
- The DC IN Jack is at SELV (Safety Extra Low Voltage).
- The line connections are at TNV (Telecommunication Network Voltage).

## Setting the selector switches

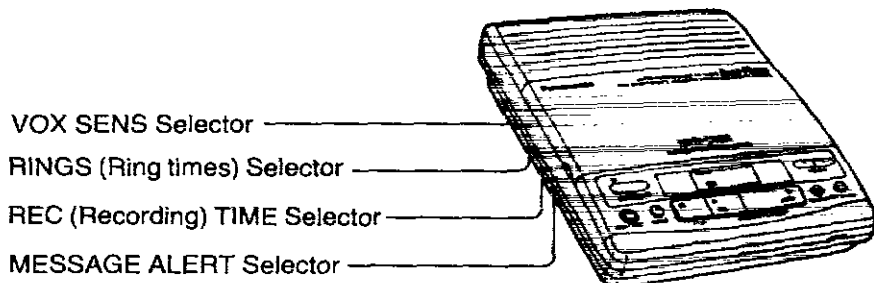

### RINGS (Ring times) Selector

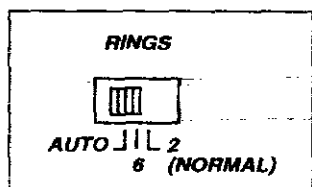

The RINGS selector (answer mode selector) has three positions as follows:

- **Position "2"** may be referred to as "NORMAL" as it enables the machine to answer incoming calls in a reasonably short time. The machine answers the call on the 2nd ring.
- **Position "6"** makes the machine answer on the 6th ring.
- **Position "AUTO"** (also known as "Toll Saver") can be used so that when you are calling in to your machine to get messages, you will know without being charged for the call if there are any new messages.

"NORMAL" switch position should be generally selected unless you specifically wish to take advantage of the "toll saver facility".

Callers are generally accustomed to their calls being answered within 10 seconds and most callers abandon the call in under 45 seconds if no reply is obtained. This machine will answer incoming calls in under 10 seconds if required.

#### Toll saver

When you call the unit from a touch tone telephone, the number of rings before the unit answers informs you if there are any new messages.

- If the unit answers on the 2nd ring: There is at least one new message.
- If the unit answers on the 6th ring: There are no new messages.

Hang up immediately when you hear the 3rd ring. The 3rd ring indicates there are no new messages. This will save you being charged for the call.

## REC (Recording) TIME Selector

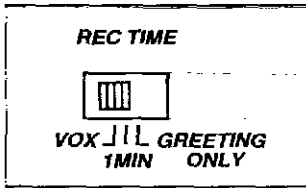

Used to select the caller's recording time.

**VOX:** Unlimited.

**1 MIN:** Limited to 1 minute.

**GREETING ONLY:**

When a call comes in, the unit answers the call, plays the greeting message, then hangs up. The unit will not record any caller's message.

## MESSAGE ALERT Selector

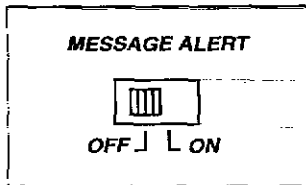

When you come home, you can be informed that new messages have been recorded by the presence of an audible beep.

**ON:** When new messages have been recorded, a short beep sounds every 10 seconds.

The beeping stops after the messages have been played back.

**OFF:** No beep sounds.

## VOX SENS Selector

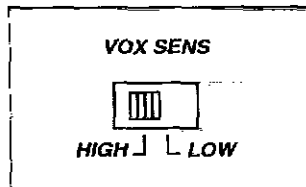

If either the tape continues to run after a caller has replaced his handset or there are long pauses between or after messages, set the selector to the position "LOW". (Normally the switch is preset to the position "HIGH".)

## Time and day adjustment

TIME CHECK Button

DAY Button

HOUR Button

MIN Button

To increase the volume,  
press ▲.  
To decrease the volume,  
press ▼.

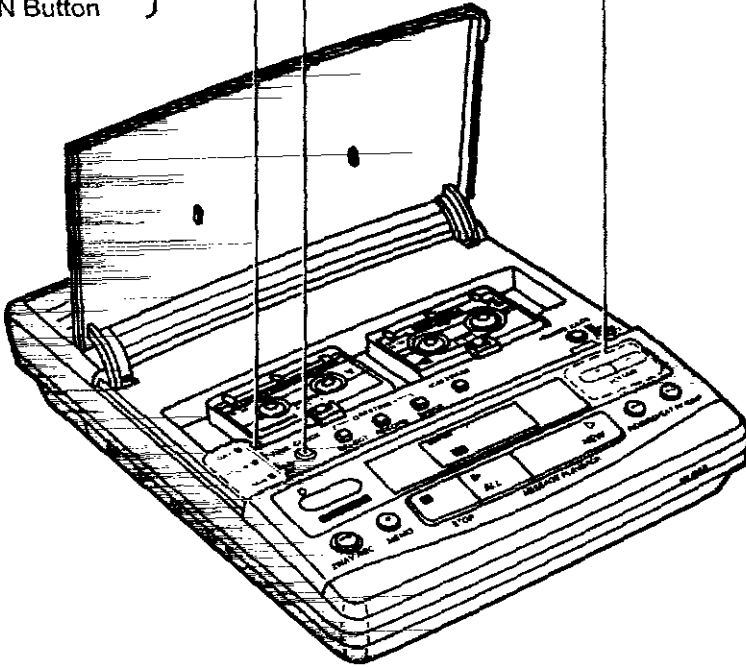

### Notes:

- During a power failure, the programmed time and day retention time is approximately 3 hours.
- If "⌚" flashes, it means that the programmed time and day have been cleared. In this case, adjust the time and day again.

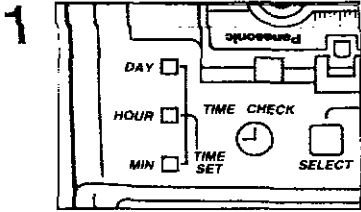

Press the DAY button repeatedly to adjust the day.

—The unit announces the day.

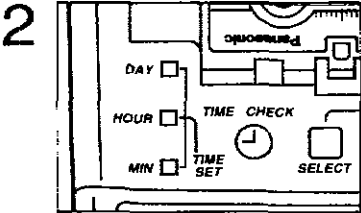

Press the HOUR button repeatedly to adjust the hour.

—The unit announces the hour.

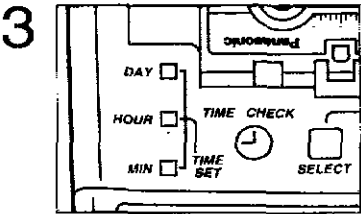

Press the MIN button repeatedly to adjust the minute.

—The unit announces the minute.  
—The clock starts working.

### Voice Time and Day Stamp

You know when a caller's message was recorded as the synthesized voice will announce the time and day of recording after each message.

### To check the time and day

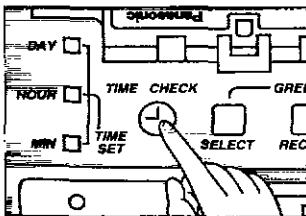

Press the TIME CHECK button.

—The unit announces the programmed time and day.

# Recording a personal greeting message

You can record two greeting messages.

**First greeting:** Its recording time is limited to 30 seconds. So you may leave a short message to your callers.

**Second greeting:** This is an extended greeting message. Its recording time is limited to 2 minutes 45 seconds.

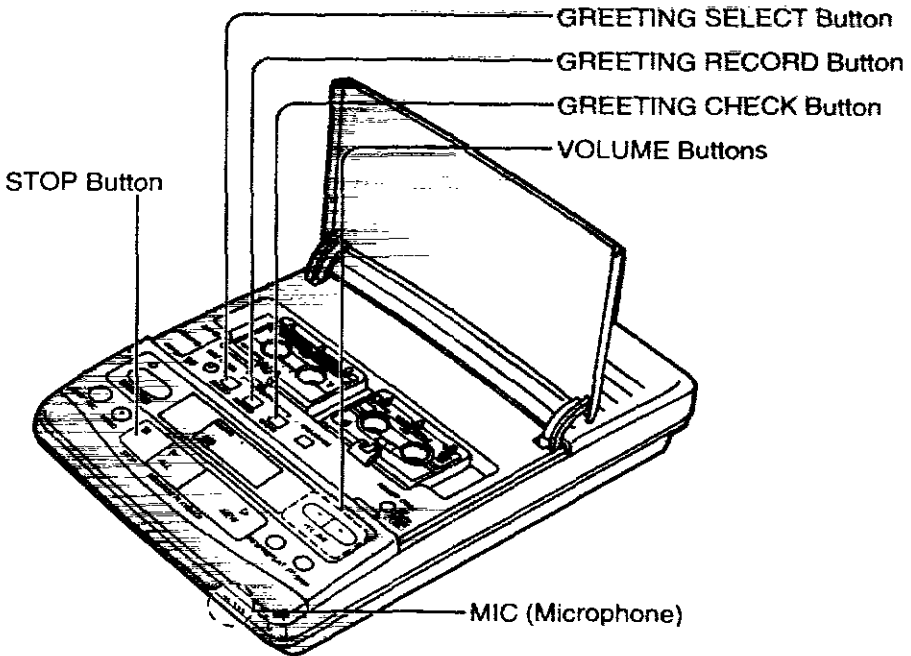

## Notes:

- It is helpful to include a statement of your answering telephone number with the exchange name or national code in the greeting message. A greeting message begins within 3 seconds of answering, of paytone ceasing, or of answering ceasing, as appropriate.
- Paytone may be received after answering calls from some types of payphone and may persist for up to 13 seconds. The greeting message should be constructed so as to ensure that a greeting message containing the identity of the called line and, where appropriate, the invitation to record, will be heard by payphone callers after paytone has ceased.

Do not pause for over 5 seconds while recording. If 6 beeps sound while recording and "Record greeting again." is announced, start again from step 2 after resetting the greeting message tape.

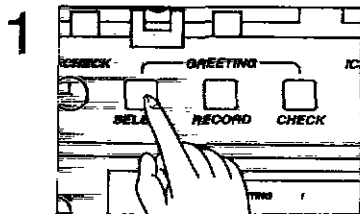

Press the GREETING SELECT button to select greeting 1 or 2.

First greeting is selected.

Display: GREETING -

Second greeting is selected.

Display: GREETING -

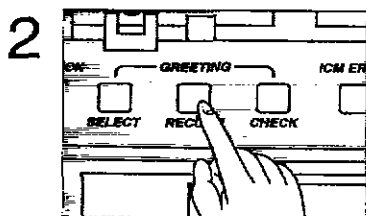

Press the GREETING RECORD button, then release it.

—"Record greeting after the beep." is announced, followed by a long beep.

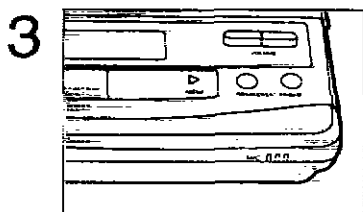

Immediately after the long beep, speak clearly and loudly, 20 cm (8") away from the MIC (microphone).

—The display shows the elapsed recording time and "RECORDING" flashes.

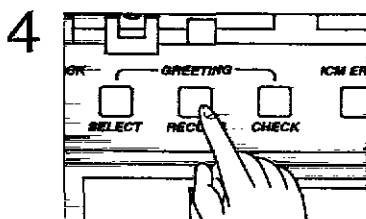

When you finish recording, press the GREETING RECORD or the STOP button.

# Pre-recorded greeting messages

The unit has two pre-recorded greeting messages.

## To select the pre-recorded greeting message

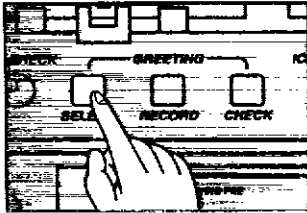

Press the GREETING SELECT button to select the pre-recorded message.

- Display shows: **GREETING** — **PRE**
- The pre-recorded greeting message is played back automatically.

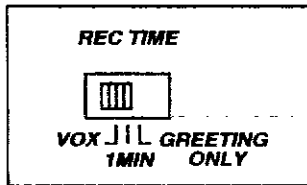

When the REC TIME selector is in the VOX or 1 MIN position:

**Pre-recorded greeting message 1** is selected.

"Hello, we are not available now. Please leave your name and phone number after the beep. We will return your call."

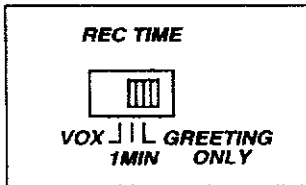

When the REC TIME selector is in the GREETING ONLY position:

**Pre-recorded greeting message 2** is selected.

"Hello, we are not available now. Please call again. Thank you for your call."

### Note:

- If there is no room left on the incoming message tape to record the next caller's message, the "GREETING ONLY" mode is selected and the pre-recorded greeting message 2 will be played automatically for the caller. No incoming messages will be recorded.

## Checking the greeting message

You can play back and check your recorded greeting message.

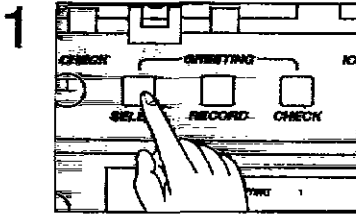

Press the GREETING SELECT button to select the greeting message you want to check.

—The selected greeting message is marked on the call counter.

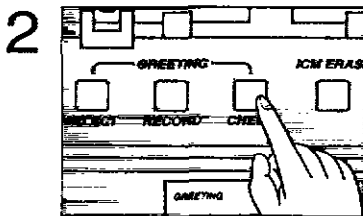

Press the GREETING CHECK button to play back the greeting message.

—Adjust the speaker volume using the VOLUME buttons.

## Adjusting the VOLUME control

There are 8 levels of speaker volume, and you can adjust it to your desired level using the VOLUME buttons, 0 (minimum) through 8 (maximum).

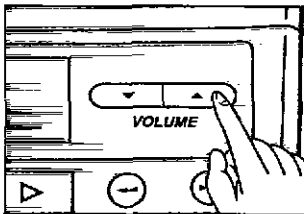

To increase the volume, press ▲.

To decrease the volume, press ▼.

—The display shows the selected volume level for 3 seconds.

## **Samples of greeting messages**

### **When the REC TIME selector is in the VOX (unlimited) position:**

"Hello, this is (your name and/or number). Sorry, I cannot take your call. Please leave your message after a long beep. Thank you."

### **When the REC TIME selector is in the 1 MIN position:**

"Hello, this is (your name and/or number). Sorry, I cannot take your call. Please leave your message after a long beep. Your recording time is up to 1 minute. Thank you."

### **When the REC TIME selector is in the GREETING ONLY position:**

"Hello, this is (your name and/or number). Sorry, I cannot take your call. If you call back tomorrow, I'll be happy to talk to you. Thank you."

## Setting the greeting monitor function

You can choose if you hear the greeting message or not while monitoring calls.

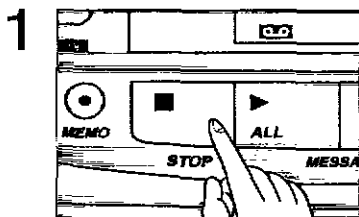

Press the STOP button until the display shows "P".

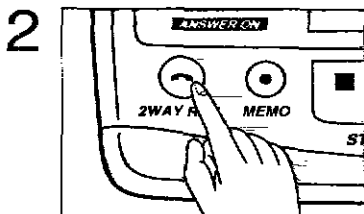

**If you want to hear the greeting message:**

Press the 2WAY REC button until "1 (ON)" is displayed.

**If you do not want to hear the greeting message:**

Press the 2WAY REC button until "0 (OFF)" is displayed.

- Each time you press the 2WAY REC button, "1 (ON)" or "0 (OFF)" will change alternately.
- Wait for 7 seconds after setting. Then the setting indicated on the display is stored.
- To check the current setting, repeat from step 1 to 2.

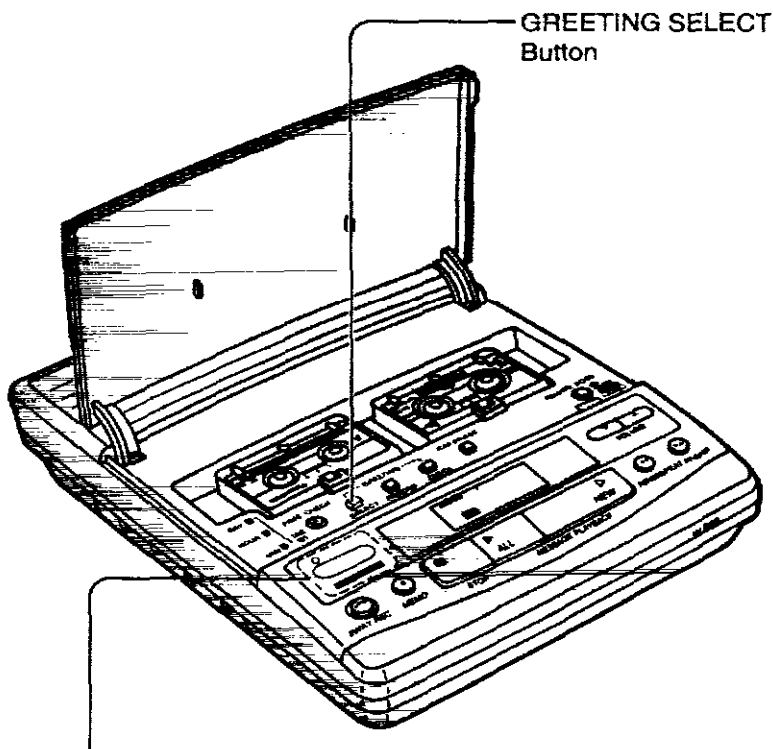

# Automatic answering operation —

When a call is received, the unit plays back your greeting message, and records the caller's message. After the call is completed, it will be ready for the next call automatically.



ANSWER ON Button and Indicator

The answering system works when the **ANSWER ON** indicator light is on.



**ANSWER ON**

## Setting the unit to answer calls

Set the unit as follows to answer a call and record messages.

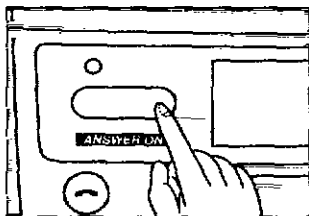

Press the ANSWER ON button to turn the answering system on.

- “Answer set” is announced.
- The ANSWER ON indicator light is on and the unit is ready to receive calls.

### To turn the unit off

If you do not want the unit to answer the call, press the ANSWER ON button, and confirm that the ANSWER ON indicator light goes out.

When you turn the unit off, the unit will answer and record an incoming call if rung 20 times (Remote turn on).

## Selecting the greeting message

Which greeting message is played back to the caller depends upon the selection of 1, 2 or PRE (Pre-recorded greeting message).

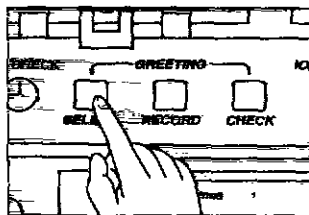

Press the GREETING SELECT button.

- The selected greeting message is marked on the display.

First greeting is selected.

Display: GREETING -

Second greeting is selected.

Display: GREETING -

Pre-recorded greeting is selected.

Display: GREETING -

# Listening to the recorded messages

- the NEW MESSAGE indicator flashes.
- the call counter shows the number of recorded messages up to 30.
- a short beep sounds every 10 seconds if the MESSAGE ALERT selector is set to the ON position.

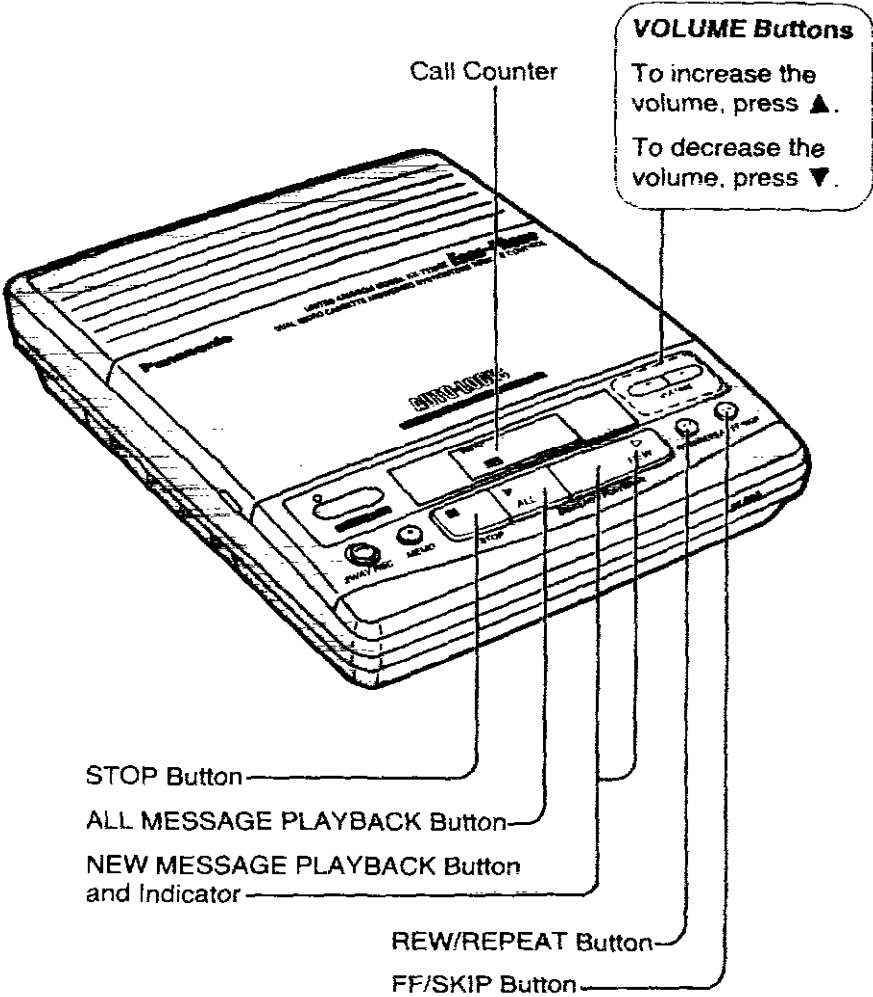

## Listening to new messages only

Only new messages are played back. Messages once reviewed will not be played back.

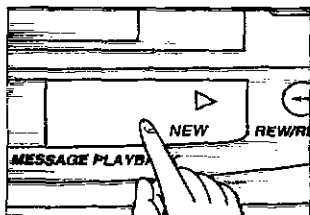

Press the **NEW MESSAGE PLAYBACK** button.

- The unit plays back new messages.
- The call counter shows the message number being played back.

## Listening to all the recorded messages

All the recorded messages—including those previously reviewed or saved—will be played back from the beginning of the tape.

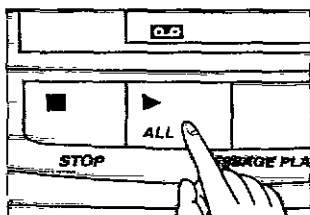

Press the **ALL MESSAGE PLAYBACK** button.

- The unit plays back all the recorded messages.
- The call counter shows the message number being played back.

### **AUTO-LOGIC**

By pressing a **MESSAGE PLAYBACK** button, the unit automatically;

- rewinds the tape and plays back the messages
- beeps once after each message with announcement of time and day
- stops the tape and announces "End of final message" after the last message has been played
- prepares to record new messages after the old messages

The following functions are available during message playback.

### To repeat the message during playback

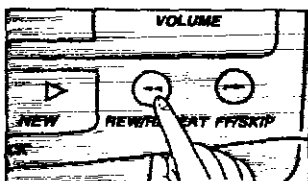

Press the REW/REPEAT button.

—The unit rewinds the tape to the beginning of the message and starts playback again.

#### Note:

—If you press the REW/REPEAT button within 5 seconds of playing back the message, the unit will play back messages from the one before.

### To skip the message during playback

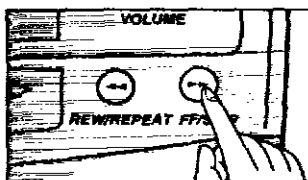

Press the FF/SKIP button.

—The unit forwards the tape to the beginning of the next message and starts playback again.

### To stop the operation

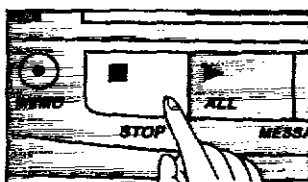

Press the STOP button to stop playing back, or other operation.

In case your unit is not in playback operation.

When you press the REW/REPEAT button, the unit rewinds the tape to the beginning automatically.

When you press the FF/SKIP button, the unit forwards the tape to the end of the last message automatically.

# Saving some old messages

If you do not want to clear away some old messages previously recorded, you can save them.

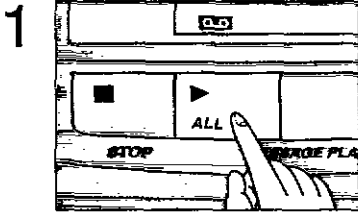

Press the ALL MESSAGE PLAYBACK button to play back the messages.

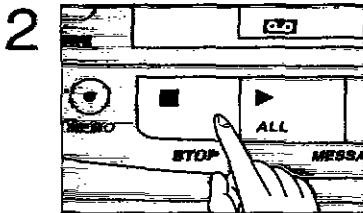

Press the STOP button at the end of the message you want to save.

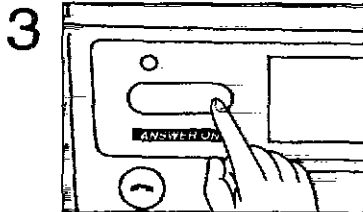

Press the ANSWER ON button to turn on the answering system.

- The ANSWER ON indicator light is on.
- The new messages will be recorded after the message(s) you have saved.
- The call counter shows the total number of messages on the tape.

## Resetting the incoming message tape

To record new messages from the beginning of the incoming message tape, rewind the incoming message tape.

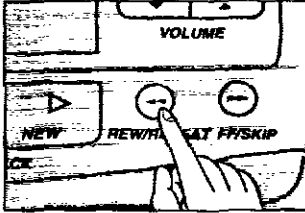

Press the REW/REPEAT button after playback.

- The new messages will be recorded from the beginning of the tape.
- The call counter shows "0".

## Erasing the recorded messages

After playback, you can erase the messages on the tape.

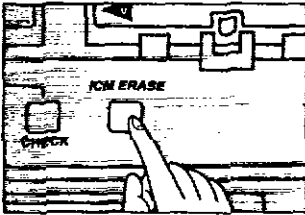

Press the ICM ERASE button.

- The unit erases the messages while the tape being rewound.
- The call counter shows "0".
- To stop erasing, press the STOP button.

# Recording your own message

You may record a personal message on the ICM tape. It can be heard by anyone playing back messages remotely or manually.

1

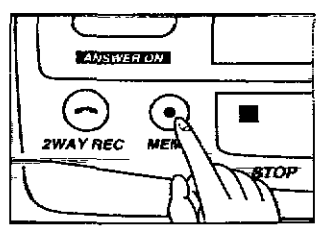

Press the MEMO button.

- A beep sounds.
- The number on the call counter increases by one.

2

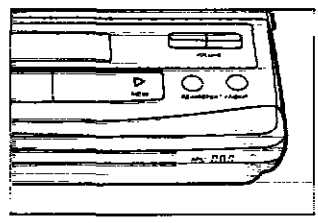

Immediately after the beep, speak clearly and loudly, 20 cm (8") away from the microphone.

3

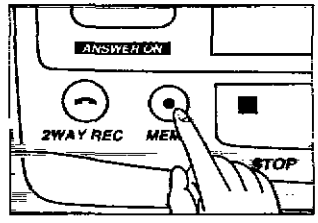

To stop recording, press the MEMO or the STOP button.

# Recording a telephone conversation

---

While speaking with someone on the telephone, you can record your conversation.

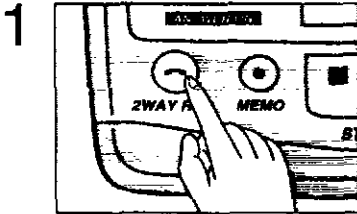

During your conversation, press the 2WAY REC button.

- A beep sounds.
- The number on the call counter increases by one.



Continue your conversation.

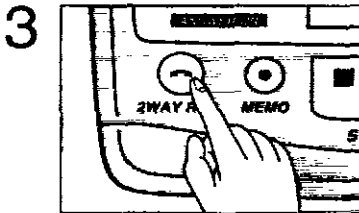

To stop recording, press the 2WAY REC or the STOP button.

## Notes:

- When you record 2-way telephone conversations, you should inform the other party that the conversation is being recorded.
- If the 2WAY REC button is pressed, a beep sounds every 15 seconds.

# Monitoring incoming calls ---

While an incoming call is being recorded, you can monitor the caller's voice through the speaker and answer it if you want.

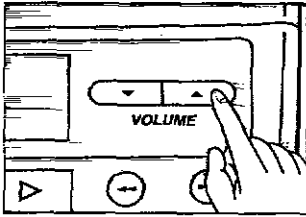

Adjust the volume using the **VOLUME** buttons.

## Helpful hints:

- To answer a call while monitoring, lift the handset of any telephone on the same line. The unit will stop recording.
- You can also answer the call while the unit is playing the greeting message in the same way.  
If the unit does not stop playing the greeting or recording the incoming message, press the hookswitch for about 1 second and then release it again.
- You can choose whether you hear the greeting message while monitoring calls (see page 21).

# Remote operation from a touch tone phone

---

You can operate your answering system remotely using a touch tone telephone while you are away from home.

The synthesized voice gives directions on how to operate your unit.

—To operate the unit directly, skipping the order of the voice menu, see pages 36 through 40.

—For Toll Saver feature, see page 12.

## Setting the remote code number

The remote code number prevents unauthorized persons from accessing your unit and listening to your messages. You can choose any 2-digit number (00 to 99) for your remote code number.

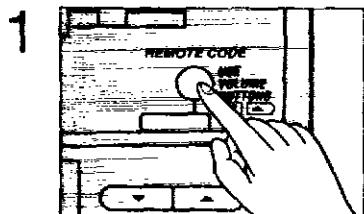

Press the REMOTE CODE button.

—The display shows the current remote code number.

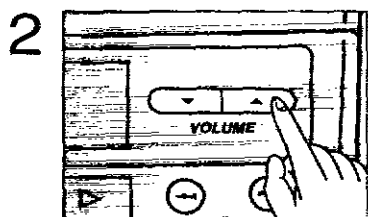

Within 7 seconds of pressing the REMOTE CODE button, press the VOLUME buttons (▲ or ▼) repeatedly to select the number.

—Wait for 7 seconds after selecting the number.  
The number on the display is then stored.

## To check the remote code

Press the REMOTE CODE button.

The display shows the programmed remote code number for 7 seconds.

## Going into voice menu

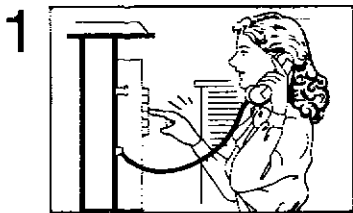

Call your unit from a touch tone telephone.

You can identify a touch tone telephone because it has a \* button, a # button and each button when pressed produces a different tone from any other button.

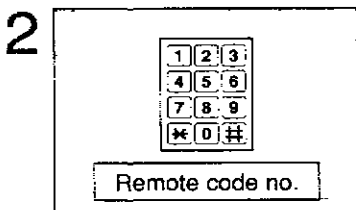

Press your remote code number during greeting message playback.

—The unit tells you the number of recorded messages.

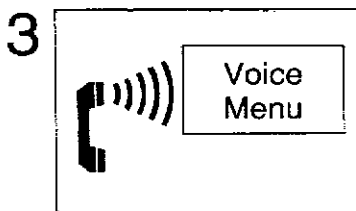

After 3 seconds, the unit starts the voice menu function.

—“Press 1 to play back all messages, press 2 for other functions.” is announced.

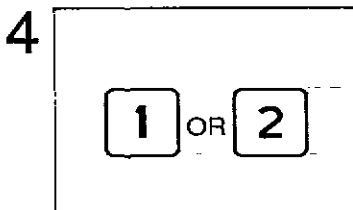

Press “1” to use the announced feature or press “2” to proceed to other functions.

# List of the voice menu

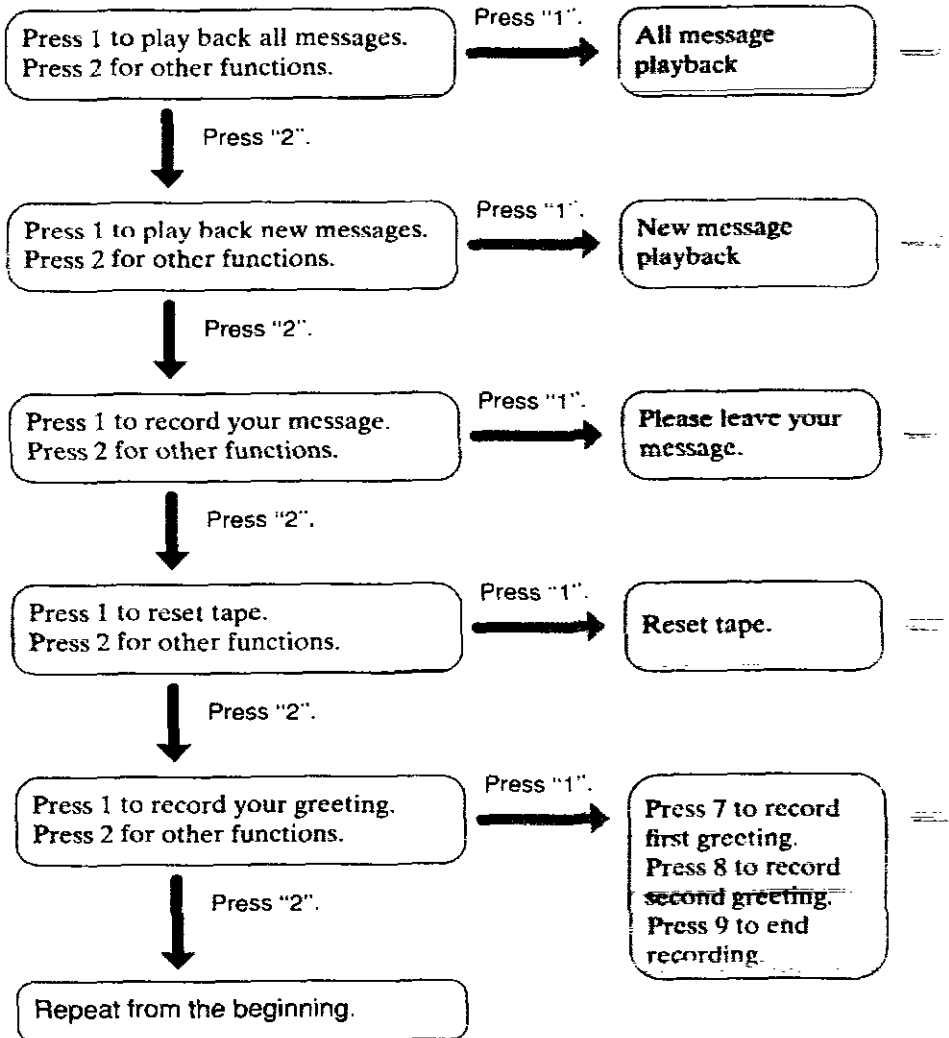

### **All messages playback**

The unit plays back all the recorded messages. At the end of the last message, "End of final message" is heard.

If you want to continue the voice menu operation, wait for 5 seconds, the unit will restart voice menu from the beginning.

If you hear "End of tape" after retrieving your messages, the tape is full. You must reset the tape.

### **New message(s) playback**

The unit plays back only messages that have not been previously heard.

### **Leaving your message**

You can leave a memo message.

1. Speak after announcement "Please leave your message."
2. When you finish recording, hang up.

### **Reset tape**

You can reset the tape to record the new messages from the beginning of the tape.

### **Recording a greeting message**

You can re-record your greeting message.

1. Press "7" or "8".  
You hear announcement "Recording first (second) greeting", followed by a long beep.
  2. Speak after the long beep.
  3. When you finish recording, press "9".
- Do not pause for over 4 seconds while recording, or the call is terminated forcibly.

# Direct remote operation (Basic)

You can also retrieve your messages and control the unit directly in lieu of using the voice menu.

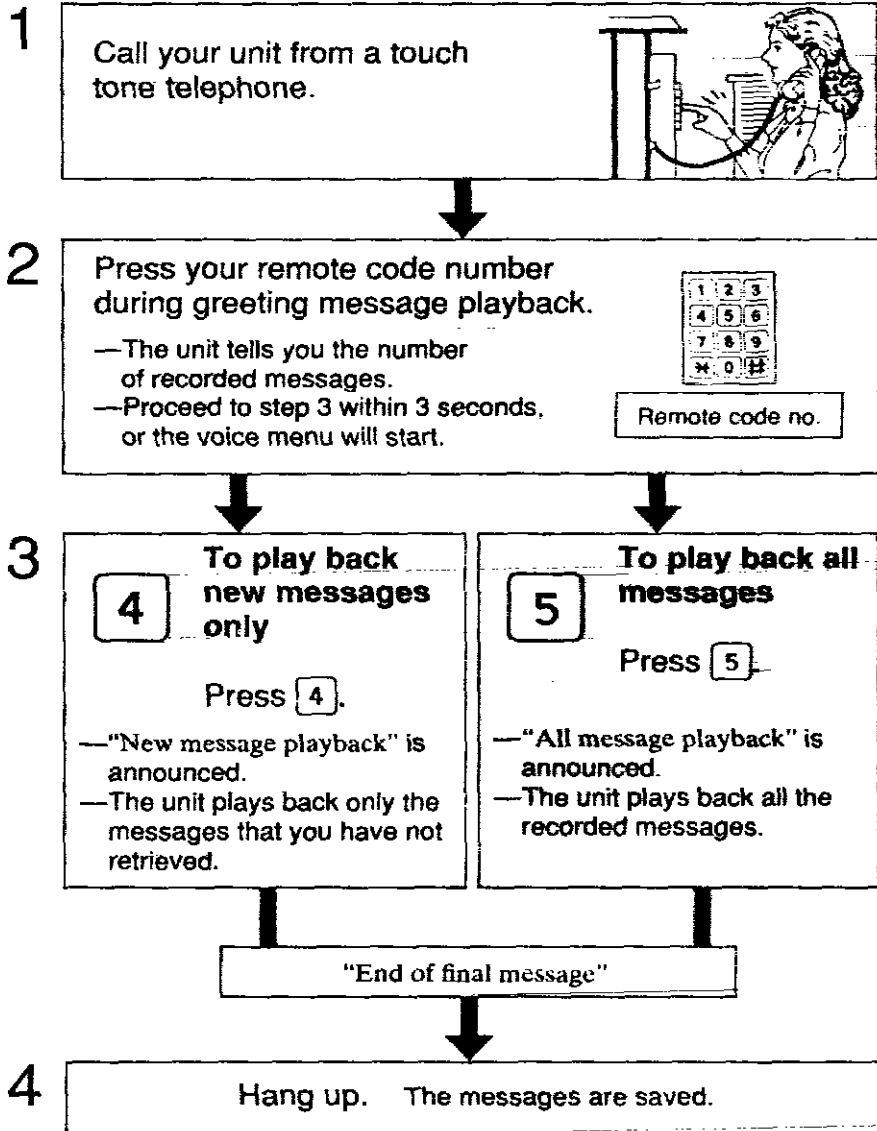

## During playback

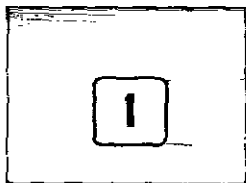

### Repeating a message

Press **1**.

- “Repeat” is heard. The unit resumes playback at the beginning of the message.
- If you press “1” within 5 seconds of playing a message the unit will rewind to the start of the previous message.

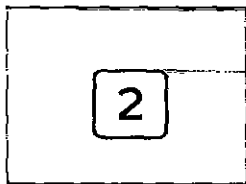

### Skipping a message

Press **2**.

- “Skip” is heard. The unit starts to play back the next message.

## To reset the tape after playback

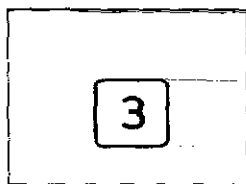

Press **3** within 5 seconds.

- “Reset tape” is heard.
- When you play back all messages, the unit rewinds the tape to the beginning and “The tape is reset.” is heard.
- When you play back only new messages, the unit rewinds the tape to the beginning of new messages and a beep sounds.

### **If you want to rewind the tape to the beginning after playing back only new messages:**

Press **3** again after hearing a beep.

- The unit rewinds the tape to the beginning.

### **If you want to cancel the reset:**

Press **2**.

## Direct remote operation (Advanced)

1 Call your unit from a touch tone telephone.



2 Press your remote code number during greeting message playback.

- The unit tells you the number of recorded messages.
- Proceed to step 3 within 3 seconds, or the voice menu will start.

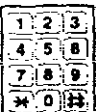

Remote code no.

3 **To re-record the greeting message**

- ① Press **7** to re-record the first greeting message.  
Press **8** to re-record the second greeting message.
  - The unit rewinds the tape, then "Record greeting after the beep." is announced, followed by a long beep.
- ② Speak immediately after a long beep.
  - Do not pause for over 4 seconds, or the call is terminated forcibly.
- ③ To stop recording, press **9**.
  - The newly recorded greeting message will be played back.
  - If you want to re-record, start again from step ①.

4 Hang up to end the remote operation.

**To skip the greeting message (For outside callers)**

Press **\*** **1** during greeting message playback.

—Callers can record their messages without listening to your greeting message.



**To change the greeting message to the first**

Press **\*** **1**.

**To change the greeting message to the second**

Press **\*** **2**.

**To change the greeting message to the pre-recorded**

Press **\*** **3**.

—The selected greeting message is played back.

## To turn the answering system on

You can easily turn the answering system on from another location.

1

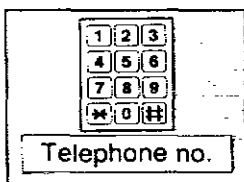

Call your unit.

2

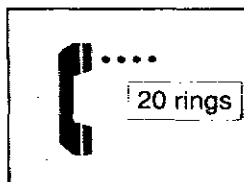

Wait for 20 rings.

—The unit will answer and the greeting message will be heard, hang up.

## To turn the answering system off

1. Call your unit from a touch tone telephone.
2. Press your remote code number during greeting message playback.  
—The unit announces the number of recorded messages.
3. Press .

*"Answer off. Thank you for your call." is announced.*

Then hang up.

## To continue playback

During remote operation, the unit will stop and "Press 9 (nine) to continue." is announced in the following circumstance.

—every 2 minutes 40 seconds after pressing a command button.

Press  within 10 seconds of the announcement to listen to further messages.

### OPERATION FROM TONE PHONE

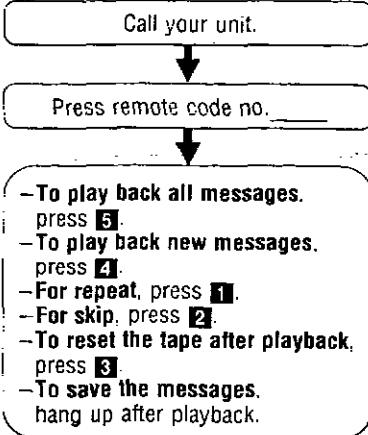
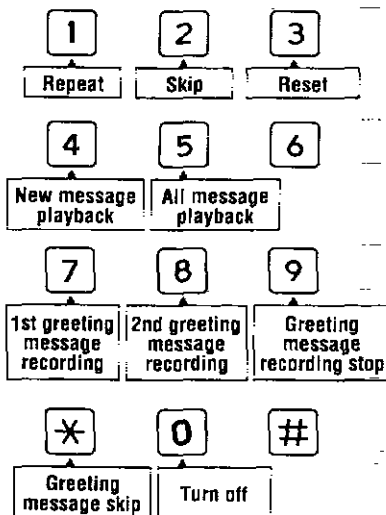

When you press any button, press it for about 1 second.

### OPERATION FROM TONE PHONE

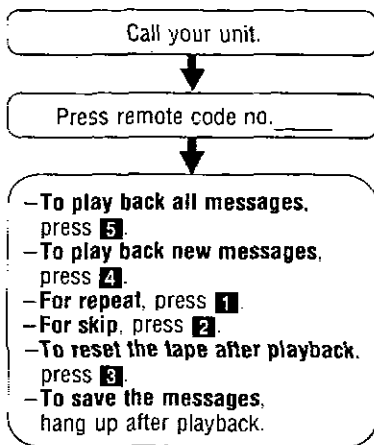
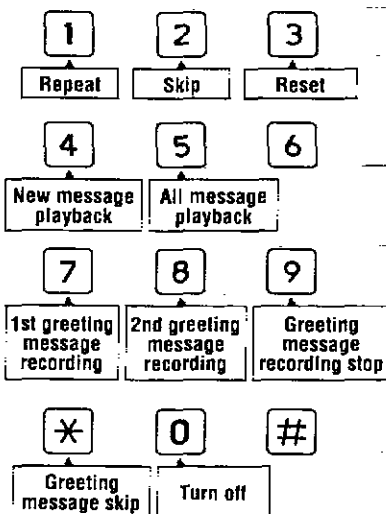

When you press any button, press it for about 1 second.

Call your unit.

Press remote code no. \_\_\_\_\_

**To re-record the greeting message:**

1. Press **7** to re-record the first greeting message.  
OR  
Press **8** to re-record the second greeting message.
2. Speak after a long beep. Do not pause for over 4 seconds.
3. When finished, press **9**.

-The unit will enter into the Voice Menu mode if you do not press a button.

**To skip the greeting message,** press **\***.

**To turn the answering system off,** press **0** then hang up.

**To change the greeting message to the first greeting;**  
Press **x** → **1**.  
**To the second greeting;**  
Press **x** → **2**.  
**To the pre-recorded greeting;**  
Press **x** → **3**.  
-The unit will play back the greeting message

-To continue playback, press **9** within 10 seconds of the announcement.

-To turn the answering system on, call your unit and wait for 20 rings. The unit will answer, then hang up.

Call your unit.

Press remote code no. \_\_\_\_\_

**To re-record the greeting message:**

1. Press **7** to re-record the first greeting message.  
OR  
Press **8** to re-record the second greeting message.
2. Speak after a long beep. Do not pause for over 4 seconds.
3. When finished, press **9**.

-The unit will enter into the Voice Menu mode if you do not press a button.

**To skip the greeting message,** press **\***.

**To turn the answering system off,** press **0** then hang up.

**To change the greeting message to the first greeting;**  
Press **x** → **1**.  
**To the second greeting;**  
Press **x** → **2**.  
**To the pre-recorded greeting;**  
Press **x** → **3**.  
-The unit will play back the greeting message.

-To continue playback, press **9** within 10 seconds of the announcement.

-To turn the answering system on, call your unit and wait for 20 rings. The unit will answer, then hang up.

# Troubleshooting guide ---

**The unit does not work, and/or I cannot remove the tape from the unit.**

- Plug in the AC adaptor again.

**The answering system is on but no incoming messages are recorded.**

- The REC TIME selector is set to the GREETING ONLY position. Change it to the VOX or 1 MIN position.
- The incoming message tape is full. Reset it (see page 28).
- The greeting message is recorded improperly or not recorded, so no one can leave a message. Check and record a new greeting message.
- The VOX SENS switch is set incorrectly for your telephone line. Try the other setting.

**The call counter shows "Err".**

- The greeting message tape is not inserted. Insert the tape.
- The greeting message tape might be broken. Replace it with a new one.

**6 quick beeps sound during greeting message recording, and it results in failure.**

- Re-record your greeting message. Speak clearly and loudly, and do not pause for over 5 seconds while recording.

**When a message is played back, the sound level is low, even if the volume is high.**

- Clean the heads (see page 44).
- Replace the incoming message tape with a new one.

**While operating the unit, the AC adaptor feels warm.**

- This is a normal condition.

**The unit does not answer remotely.**

- The answering system is turned off. To set the unit to answer the call, call your unit and wait for 20 rings (see page 40).

**I press the dial button of a touch tone phone after the unit answers, but the answering system does not respond.**

- Make sure that you press your correct remote code number. To check your remote code number (see page 32).
- The answering system may not respond if a remote touch tone phone produces tones that are too short to activate the unit (for example B.T. public telephones). If the telephone produces tones for as long as you hold down a button press each button for about 1 second each.
- If your unit does not respond you may need to purchase the optional remote controller KX-A74. Please contact your supplier for advice.

**The incoming message tape continues to run after a caller hangs up.**

- Set the VOX SENS selector to "LOW" (see page 13).
- Set the REC TIME selector to the 1 MIN position (see page 13).
- You may request B.T. to provide a CPC pulse (K-Break).

**When you lift up the telephone handset to answer a call, the greeting is heard and it does not stop.**

- Press the hookswitch on the telephone about 1 second. Then you can answer a call.

# Maintenance

## Tape deck

Since the head and capstan assemblies are in contact with the tape, dirt and residue from the tape may easily adhere to these parts, causing distortion. These parts should be cleaned periodically in the manner described below.

Clean the head surface, pinch roller and capstan with a cotton swab. If these surfaces are extremely dirty, wipe them with the cotton swab dampened with alcohol, then wipe them with a dry soft cloth.

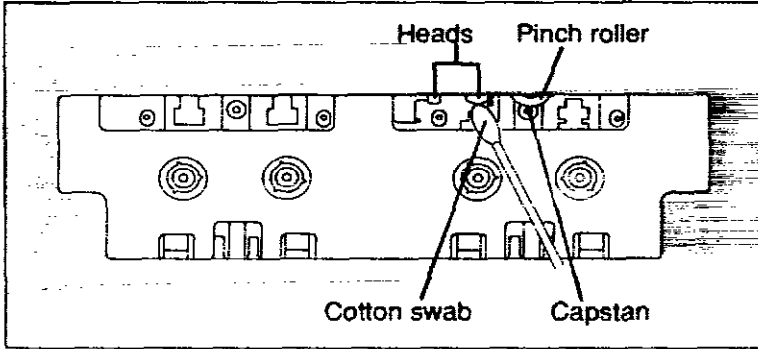

## Notes:

- Do not bring magnetic or metal objects, such as a screwdriver, near the head assemblies, as such objects could magnetize the heads.
- Do not oil any part of the unit.

### Cassette tape

- For optimum sound quality and performance, we recommend that you **use the opposite side (side-2) after six months and replace the tape with a new one every year**, assuming that the unit answers about ten calls a day.
- Never place a cassette tape near a magnetic source, such as a *magnet* or a *TV set*; because it may erase or distort the recorded message on the tape.
- Slack in the tape can be tightened by rotating the tape reel with an instrument like a pencil, as shown.

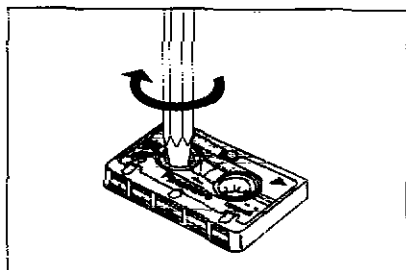

### Cassette panel installation

If the panel comes off, replace it by pushing as shown.

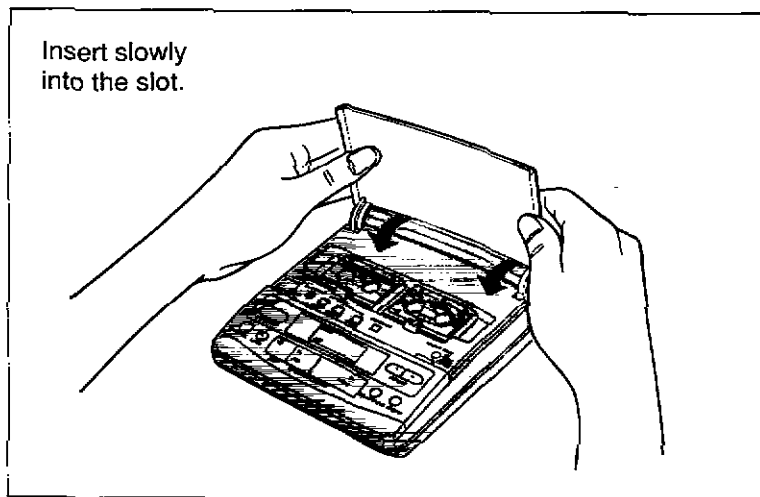

# Safety instructions

---

Take special care to follow the safety suggestions listed below.

## Safety

- 1) **Power Source:** The unit should be connected to a power supply only of the type described in the operating instructions or as marked on the unit.
- 2) **Non use Periods:** When the unit is not used, turn the power off. When left unused for a long period of time, the unit should be unplugged from the household AC outlet.

## Installations

### Environment

- 1) **Water and Moisture:** Do not use this unit near water—for example, near a bath tub, washbowl, sink, etc. Damp basements should also be avoided.
- 2) **Heat:** The unit should be situated away from sources of heat such as radiators, cookers, etc. It also should not be placed in rooms where the temperature is less than 5°C (41°F) or greater than 40°C (104°F).

### Placement

- 1) **Stacking:** Do not place heavy objects on top of this unit.
- 2) **Foreign Material:** Care should be taken so that objects do not fall onto and liquids are not spilled into the unit. Do not subject this unit to excessive smoke, dust, mechanical vibration, or shock.
- 3) **Surface:** Place the unit on a flat level surface.
- 4) **Magnetism:** The unit should be situated away from equipment or devices that generate a strong magnetic field.

### WARNING:

TO PREVENT THE RISK OF FIRE OR ELECTRICAL SHOCK, DO NOT EXPOSE THIS PRODUCT TO RAIN OR ANY TYPE OF MOISTURE.





# **Panasonic Business Systems U.K.**

**WILLOUGHBY RD.  
BRACKNELL, BERKSHIRE  
RG12 4FP**



## **POST CARD**



**The Telephone Manager  
British Telecom Sales Department**

..... **Area**  
.....  
.....

## **GUARANTEE**

### **CONDITIONS OF GUARANTEE**

This guarantee is in addition to and does not in any way affect any statutory or other rights of consumer purchasers. If within the applicable guarantee period, the appliance proves to be defective by reason of faulty design, workmanship or materials, we undertake subject to the following conditions to have the defective appliance (or any part or parts there of) repaired or replaced free of charge.

1. The appliance shall have been purchased and used solely within the UK and in accordance with standard operating instructions and the technical and/or Safety Standards required in the UK.
2. The purchaser will within 7 days of purchase complete the included card and send it to us for registration. Failure to return such card could result in delay in providing the guarantee service.
3. The appliance should be returned together with this guarantee and proof of date of purchase promptly on being found defective at the purchaser's risk and expense to the authorized dealer from whom the appliance was purchased or to the nearest authorized dealer. All enquiries must be through such dealers.
4. This guarantee shall not apply to damage caused through fire, accident, lightning, misuse, wear and tear, neglect, incorrect adjustment or repair, to damage caused through installation, adaption, modification or use in an improper manner or inconsistent with the technical and/or safety standards required in the country where this appliance is used, or to damage occurred during transit to or from the purchaser.
5. If at any time during the guarantee period any part or parts of the appliance are replaced with a part or parts not supplied or approved by us or of an objective quality safe and suitable for the appliance, or the appliance has been dismantled or repaired by any person not authorized by us, we shall have the right to terminate this guarantee in whole or in part immediately without further notice.
6. The purchaser's sole and exclusive remedy under this guarantee against us is for the repair or replacement of the appliance or any defective part or parts and no other remedy, including, but not limited to, incidental or consequential damage or loss of whatsoever nature shall be available to the purchaser.
7. This guarantee shall not apply to cassette tapes, batteries and any other items of limited natural life.
8. Our decision on all matters relating to complaints shall be final. Any appliance or defective part which has been replaced shall become our property.
9. The guarantee period applicable to this product shall be 12 months.

Please keep these Operating Instructions with your receipt.

### **Panasonic Business Systems U.K.**

---

Receipt No.

Date of Purchase

---

Model No.

**KX-T5206E**

Serial No.

---

185

**Panasonic Business Systems U.K.**  
Panasonic House, Willoughby Road, Bracknell,  
Berkshire RG12 4FP

Printed in the United Kingdom

**PQQX10736ZA** F0694Y1074